



ANNUAL MEETING

15-19 MAY 2020 | BOSTON, MA

EXHIBITOR GUIDE



PRACTICE MANAGEMENT PROGRAMMING PROVIDED BY THE
AMERICAN SOCIETY OF OPHTHALMIC ADMINISTRATORS

ADDITIONAL PROGRAMS

World Cornea Congress VIII – May 14-15

ASCRS REFRACTIVE DAY – May 15

ASCRS GLAUCOMA DAY – May 15

ASOA WORKSHOPS – May 15

TECHNICIANS & NURSES PROGRAM – May 15-19

AnnualMeeting.ascrs.org



Dear Exhibitor,

The American Society of Cataract and Refractive Surgery (ASCRS) and the American Society of Ophthalmic Administrators (ASOA) invite you to participate in the ASCRS and ASOA Annual Meeting, taking place May 15-19, 2020 in Boston, Massachusetts. The largest U.S. meeting dedicated exclusively to the needs of anterior segment surgeons, and their technical and practice management staff, this meeting provides unique opportunities for you to build relationships with key stakeholders who can help you achieve your marketing objectives.

In addition, we invite you to participate in the one-day ASCRS Subspecialty Day exhibit hall, being held on Friday, May 15, 2020.

This exhibit hall – which is open to all attendees of ASCRS Glaucoma Day and ASCRS Refractive Day – offers a unique opportunity for exhibitors to connect with an essential target market for your company's products and services. These one-day educational programs attracted a combined total of over 2,300 ophthalmologists and healthcare professionals in 2019.

Also, the World Cornea Congress VIII will have a 2-day dedicated exhibit hall offering exhibitors access to a projected physician attendance of more than 1,500.

The Cornea Society sponsors the World Cornea Congress, which is held approximately every 5 years and highlights the progress that has been made in both clinical and research endeavors of the international corneal community. This 2-day meeting, beginning on Thursday, May 14 will include invited speakers and paper presentations, interactive programming, networking opportunities, and surgical wet labs. There will also be a poster session each day and a dedicated World Cornea Congress VIII exhibit hall. The most recent meeting, World Cornea Congress VII, was held in San Diego in 2015.

Thank you for your commitment and dedication to ASCRS and ASOA. We appreciate all the hard work, time and effort you put into our meeting. It is our goal to continue to strive for excellence and to provide you with a spectacular meeting experience.

We look forward to seeing you in Boston!

Exhibits Manager
ASCRS ASOA

VALUE OF EXHIBITING	4
2020 ACTIVATIONS	5
2019 ATTENDANCE HIGHLIGHTS	6-7
2019 DEMOGRAPHICS	8-10
EXHIBITS & MEETINGS CONTACTS	11
OFFICAL SERVICE CONTRACTORS	12
IMPORTANT DATES	13
EXHIBIT SCHEDULE	14
SPACE ASSIGNMENTS	15
PRIORITY POINTS FOR SPACE ASSIGNMENTS	16
BOOTH FEES	17
PAYMENT SCHEDULE & METHODS	18
EXHIBIT SPACE APPLICATION	19-20
HOTELS	21-22
AFFILIATE FUNCTIONS	23-24
BIOMED HAZARDOUS WASTE, LASER SAFETY & SPECIALTY GAS	25
FDA REGULATIONS	26
EXHIBITOR APPOINTED CONTRACTORS	27
UNION JURISDICTIONS & LABOR	28
MATERIAL HANDLING & SHIPPING	29
BOSTON UNION GUIDELINES	30
BOOTHTYPES & DESIGNS	31-32
DURINGTHE EXHIBITION	33-34
EXHIBIT BOOTH MARKETING & ACTIVITIES	35-36
GENERAL RULES & REGULATIONS	37-38
ASCRS SUBSPECIALTY DAY 2019	39-48
WORLD CORNEA CONGRESS VIII	49-58

WHAT ARE THE ATTENDEES SAYING ABOUT THE ASCRS ANNUAL MEETING?

The ASCRS Annual Meeting exceeds anterior segment surgeons' expectations for some of their most important reasons for attending:

Keep up-to-date on industry trends/innovations 92%

Reason for Attending

Satisfaction (Over %s)

See new product products and developments 94%

Network with peers 93%

Innovative learning formats and sessions 96%

Offers an experience I can't replicate online 98%

Attendees' time in the exhibit hall is higher than industry average:

ASCRS Annual Meeting 7.6 hours

Healthcare Meeting Benchmark 6.9 hours

Source: Freeman Research and Insights Physician Attendee Research, 2019

ASCRS TAP ROOM

According to ASCRS research*, the two words most often used to describe the ASCRS Annual Meeting are “innovation” and “fun.” The ASCRS Tap Room strategically brings the two together to enhance the meeting experience for both attendees and exhibitors.

The ASCRS Tap Room offers a forum where attendees can grab a drink, learn about the latest technologies, devices, products and services, and network with friends and colleagues. Participating companies will have forty-five minute segment(s) to share information with attendees and engage in a facilitated Q&A session. Purposefully placed within the exhibit hall, the ASCRS Tap Room provides participating companies the opportunity to present corporate perspectives within a comfortable, welcoming environment – a place anterior segment surgeons call home.

TOUR OF EXCELLENCE

The ASCRS Annual Meeting consistently boasts a world-class exhibit hall featuring companies dedicated to meeting the needs of anterior segment surgical practices. The meeting also consistently draws nearly one thousand residents, fellows and physicians in their first five years of practice. ASCRS and ASOA recognize that connecting these future ophthalmic leaders with the companies driving technology will help expand clinical knowledge, improve clinical skills and ultimately enhance patient care.

New in 2020, ASCRS will host the Tour of Excellence. Ophthalmic program directors will guide young physicians through the exhibit hall and facilitate introductions on the exhibit hall floor with companies participating in The Thriving Practice. Program directors will receive brief backgrounders provided by each participating company featuring highlights to incorporate into introductory remarks.

These guided tours offer participating companies the opportunity to connect with current and emerging ophthalmic leaders, showcasing premier technologies and building relationships with this important audience.

IN 2019...

- Exhibiting Companies: 322
 - Meeting Attendees: 5,989
 - Exhibitor Attendees: 4,780
- Total Attendance: 10,769

Ophthalmologists by Location

U.S. Ophthalmologists
2,489

International Ophthalmologists
1,296

2019 Annual Meeting Attendance by Category

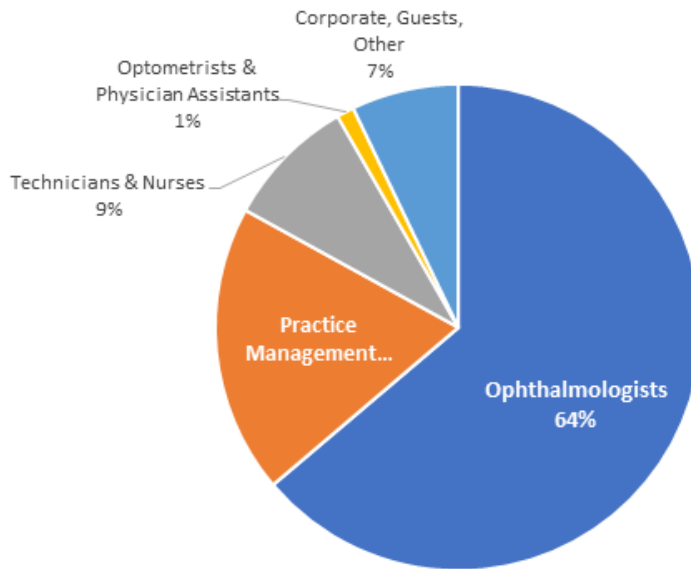

Ophthalmologists by Location

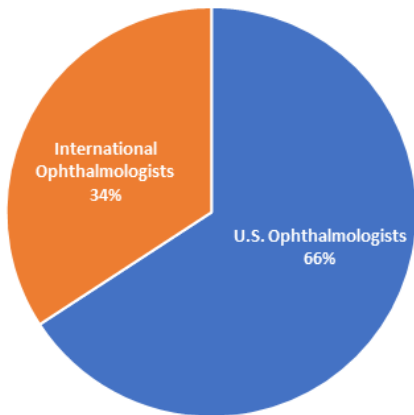

Annual Meeting Attendance Trends

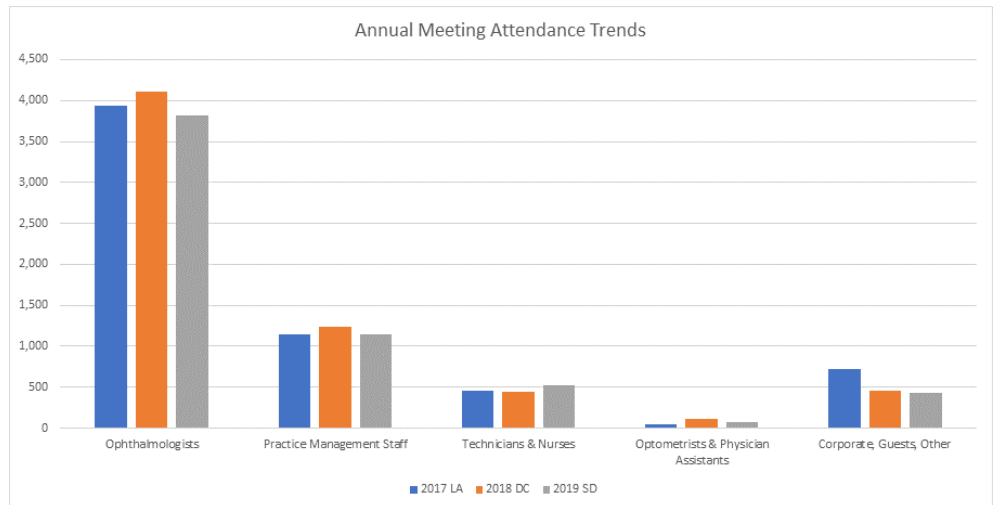

2019 All MDs by Primary Area of Practice

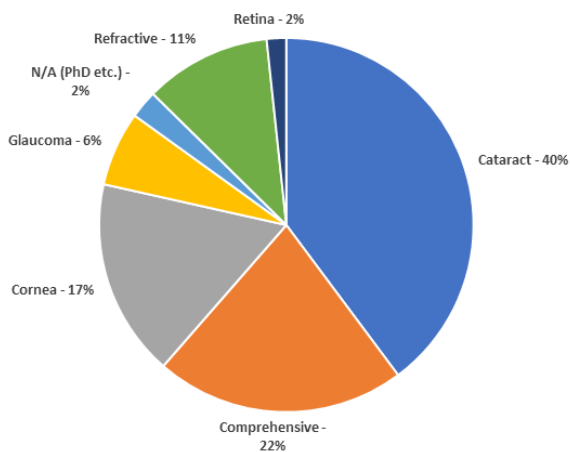

PREPARE TO CONNECT WITH THE ENTIRE OPHTHALMIC CARE COMMUNITY

The ASCRS Annual Meeting is the largest U.S. meeting for anterior segment specialists, practice management staff, and ophthalmic technicians and nurses. It's where more than 6,000 attendees come to learn directly from the world's thought leaders in ophthalmology, and return with the practical tools needed to improve their practice and enhance patient outcomes.

- Total Attendance: 5,989
- Ophthalmologists: 3,821
- Practice Management Staff: 1,150
- Technicians & Nurses: 522
- Optometrists & Physician Assistants: 69
- Other (Corporate, Guests, Press): 427

The ASCRS Anterior Segment Surgery Program, the ASOA Ophthalmic Practice Management Program, and the Technicians & Nurses Program are held simultaneously each spring. These annual meetings are the principal in education forums for ASCRS and ASOA members and feature topic-specific general sessions, exhibits, educational posters, affiliate meetings, and the ASCRS Film Festival.

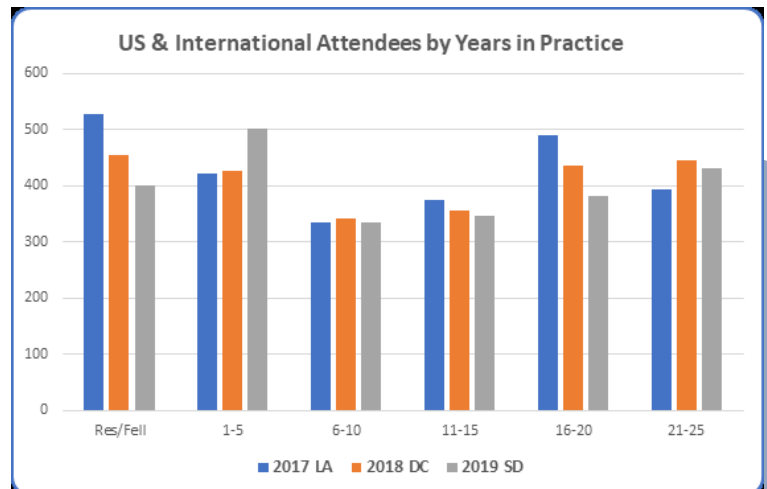
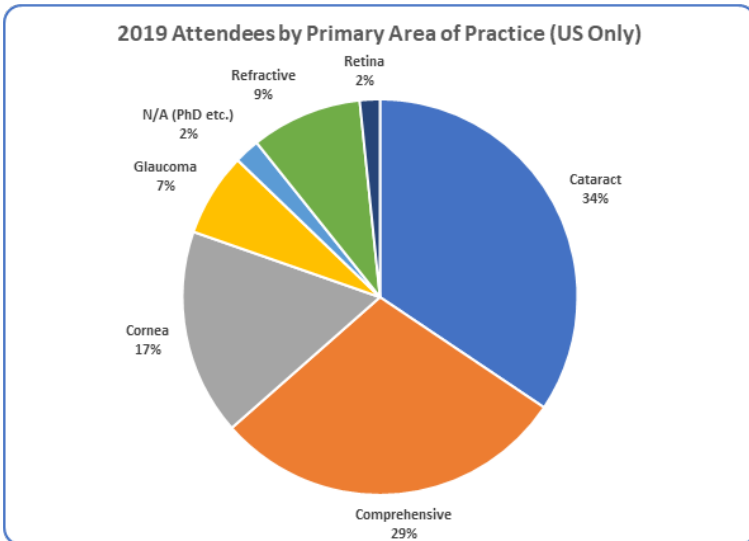
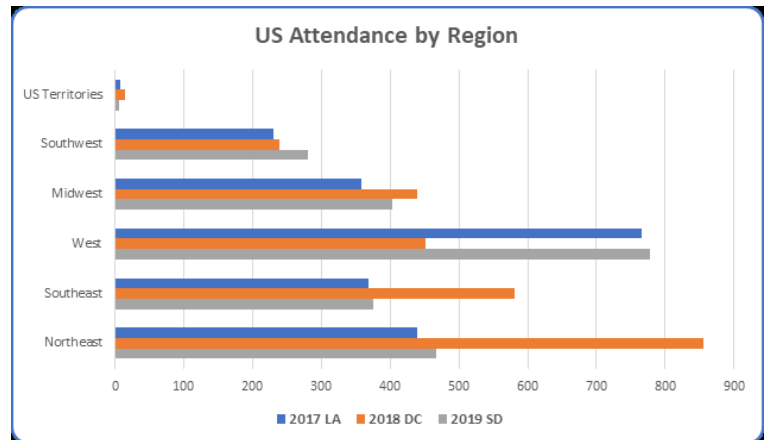
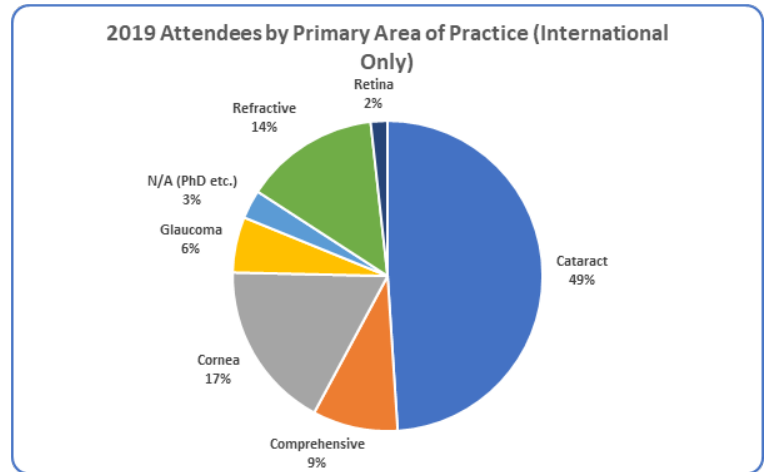

Ophthalmologists Only			
ALABAMA	18	MONTANA	5
ALASKA	5	NEBRASKA	11
ARIZONA	56	NEVADA	26
ARKANSAS	12	NEW HAMPSHIRE	12
CALIFORNIA	603	NEW JERSEY	53
COLORADO	44	NEW MEXICO	7
CONNECTICUT	14	NEW YORK	163
DELAWARE	5	NORTH CAROLINA	49
DISTRICT OF COLUMBIA	12	NORTH DAKOTA	4
FLORIDA	146	OHIO	65
GEORGIA	48	OKLAHOMA	30
GUAM	1	OREGON	42
HAWAII	19	PENNSYLVANIA	95
IDAHO	16	PUERTO RICO	5
ILLINOIS	79	RHODE ISLAND	4
INDIANA	35	SOUTH CAROLINA	27
IOWA	17	SOUTH DAKOTA	13
KANSAS	19	TENNESSEE	35
KENTUCKY	14	TEXAS	199
LOUISIANA	18	UTAH	39
MAINE	3	VIRGINIA	33
MARYLAND	57	WASHINGTON	56
MASSACHUSETTS	70	WEST VIRGINIA	7
MICHIGAN	63	WISCONSIN	29
MINNESOTA	53	WYOMING	1
MISSISSIPPI	9	TOTAL	2,489
MISSOURI	43		

*Guests, Exhibitors, and Press are not included in counts above.

All Attendees			
ALABAMA	30	MONTANA	17
ALASKA	6	NEBRASKA	25
ARIZONA	128	NEVADA	54
ARKANSAS	36	NEW HAMPSHIRE	33
CALIFORNIA	979	NEW JERSEY	83
COLORADO	87	NEW MEXICO	23
CONNECTICUT	23	NEW YORK	233
DELAWARE	6	NORTH CAROLINA	85
DISTRICT OF COLUMBIA	16	NORTH DAKOTA	12
FLORIDA	245	OHIO	126
GEORGIA	100	OKLAHOMA	67
GUAM	2	OREGON	81
HAWAII	43	PENNSYLVANIA	154
IDAHO	44	PUERTO RICO	5
ILLINOIS	120	RHODE ISLAND	5
INDIANA	57	SOUTH CAROLINA	49
IOWA	32	SOUTH DAKOTA	41
KANSAS	33	TENNESSEE	65
KENTUCKY	20	TEXAS	345
LOUISIANA	44	UTAH	68
MAINE	6	VERMONT	1
MARYLAND	86	VIRGINIA	57
MASSACHUSETTS	123	WASHINGTON	85
MICHIGAN	108	WEST VIRGINIA	12
MINNESOTA	103	WISCONSIN	52
MISSISSIPPI	24	WYOMING	3
MISSOURI	79	TOTAL	4,361

*Guests, Exhibitors, and Press are not included in counts above.

INTERNATIONAL BREAKDOWN

Ophthalmologist Only							
ALGERIA	2	ETHIOPIA	7	LEBANON	4	SPAIN	14
ARGENTINA	45	FINLAND	2	MALAYSIA	3	SWEDEN	3
ARUBA	1	FRANCE	32	MAURITIUS	1	SWITZERLAND	11
AUSTRALIA	35	GERMANY	40	MEXICO	88	TAIWAN	3
AUSTRIA	2	GHANA	1	NETHERLANDS	6	THAILAND	6
BAHAMAS	1	GREECE	5	NEW ZEALAND	6	TURKEY	33
BANGLADESH	1	GUATEMALA	6	NORWAY	4	UKRAINE	15
BARBADOS	1	HONDURAS	1	OMAN	1	UNITED ARAB EMIRATES	7
BELGIUM	9	HONG KONG	2	PAKISTAN	3	UNITED KINGDOM	28
BOLIVIA	1	HUNGARY	2	PANAMA	1	URUGUAY	4
BRAZIL	154	INDIA	94	PARAGUAY	1	UZBEKISTAN	1
CANADA	159	INDONESIA	1	PERU	19	VENEZUELA	1
CHILE	15	IRAN	1	PHILIPPINES	3	VIETNAM	5
CHINA	33	IRAQ	2	POLAND	1	ZIMBABWE	1
COLOMBIA	37	IRELAND	1	PORTUGAL	4	TOTAL	1,296
COSTA RICA	4	ISRAEL	21	ROMANIA	14		
CZECHIA	2	ITALY	29	RUSSIA	31		
DENMARK	2	JAMAICA	1	SAUDI ARABIA	20		
DOMINICAN REP	6	JAPAN	69	SINGAPORE	23		
ECUADOR	5	JORDAN	4	SLOVENIA	1		
EGYPT	19	KUWAIT	4	SOUTH AFRICA	3		
EL SALVADOR	3	LATVIA	2	SOUTH KOREA	63		

*Guests, Exhibitors, and Press are not included in counts above.

INTERNATIONAL BREAKDOWN

All Attendees							
ALGERIA	2	EL SALVADOR	3	KUWAIT	5	SOUTH AFRICA	3
ARGENTINA	45	ESTONIA	3	LATVIA	2	SOUTH KOREA	64
ARUBA	1	ETHIOPIA	7	LEBANON	4	SPAIN	15
AUSTRALIA	46	FINLAND	3	MALAYSIA	4	SWEDEN	3
AUSTRIA	2	FRANCE	35	MAURITIUS	1	SWITZERLAND	14
BAHAMAS	1	GERMANY	47	MEXICO	93	TAIWAN	5
BANGLADESH	1	GHANA	1	NETHERLANDS	7	THAILAND	6
BARBADOS	4	GREECE	5	NEW ZEALAND	13	TURKEY	33
BELGIUM	9	GUATEMALA	6	NORWAY	6	UKRAINE	16
BERMUDA	1	HONDURAS	1	OMAN	1	UNITED ARAB EMIRATES	8
BOLIVIA	1	HONG KONG	2	PAKISTAN	3	UNITED KINGDOM	31
BRAZIL	156	HUNGARY	2	PANAMA	1	URUGUAY	4
CANADA	203	INDIA	100	PARAGUAY	1	UZBEKISTAN	1
CHILE	15	INDONESIA	1	PERU	21	VENEZUELA	1
CHINA	33	IRAN	1	PHILIPPINES	3	VIETNAM	5
COLOMBIA	39	IRAQ	2	POLAND	1	ZIMBABWE	1
COSTA RICA	4	IRELAND	1	PORTUGAL	4	TOTAL	1,447
CZECHIA	2	ISRAEL	25	ROMANIA	26		
DENMARK	2	ITALY	32	RUSSIA	31		
DOMINICAN REP	8	JAMAICA	1	SAUDI ARABIA	21		
ECUADOR	5	JAPAN	79	SINGAPORE	28		
EGYPT	19	JORDAN	4	SLOVENIA	1		

*Guests, Exhibitors, and Press are not included in counts above.

ASCRS AND ASOA CONTACTS

Director of Meetings

Amber Wojtyna awojtyna@ascrs.org

Exhibits Manager & Affiliates

exhibits@ascrs.org

Meetings Coordinator

Pura Valdez pvaldez@ascrs.org

Director of Clinical Affairs and Education

Deborah Berry dberry@ascrs.org

ASOA Meeting & Programming Manager

Samantha Engler samantha@asoa.org

Director of Marketing and Communications

Maureen Varnon mvarnon@ascrs.org

Marketing and Communications Manager

Denise Monasterio communications@ascrs.org

EXHIBITOR ADVISORY BOARD

MISSION STATEMENT:

The ASCRS Exhibitor Advisory Board was designed to enhance the exhibition, programming, and Annual Meeting experience for attendees, associations, and industry through communication, education, and networking by establishing a continuous dialogue between ASCRS and its exhibitors on all matters relating to participation in the Annual Meeting. The goal of ASCRS is to be the pre-eminent ophthalmic trade-show in the industry.

Members of the Board:

Lori Oden - Alcon Laboratories

Kat Garfield - Crestpoint Management

Tom Mancuso - Diamatrix Ltd.

Michael Wolber - Oculus, Inc.

Rahim Hirji - Omeros Corporation

Larry Brooks - Practice Flow Solutions

FREEMAN IS DESIGNATED AS THE ASCRS ANNUAL MEETING SERVICE CONTRACTOR

Services at the ASCRS Annual Meeting provided by Freeman are as follows:

- Audio Visual
- Booth Cleaning
- Carpet
- Installing and the dismantling of exhibits
- Material handling

Freeman also provides specialty services:

- Booth furniture rental and accessories
- Custom exhibits and rentals
- Graphics
- Shipping

Freeman will be on site at the Exhibitor Service Center during the ASCRS Annual Meeting to assist you in coordinating any last-minute services, order additional products, and to answer any questions you may have.

BOSTON CONVENTION & EXHIBITION CENTER EXHIBITOR SERVICES

The BECEC is the exclusive vendor for the services listed below:

- Electric
- Plumbing
- Telecom/Internet
- Rigging – JCalPro (In-house provider)
- Catering – Levy Restaurants (In-house provider)

OFFICIAL SHOW CONTRACTORS

ASCRS has secured vendors as official contractors to provide the necessary services for a successful meeting and exhibition. We encourage exhibitors to utilize their services. Contact information and order forms will be available in December in your Exhibitor Service Kit.

To identify our partners, look for our Annual Meeting or association logo on all order forms and email communications.

- ADCOM Worldwide — Freight/Shipping Services
- Convention Data Services — Lead Retrieval
- Istrico Productions — Photography/Video
- onPeak — Housing
- RA Consulting — Booth Security
- Urban Jungle — Floral

OPEN

Housing officially opened May 3 in San Diego at our 2019 Annual Meeting. Please contact onPeak with any questions at: (800) 370-8282 US Toll-free | (312) 527-7300 Local / Int'l
Email ascrs-asoa@onpeak.com

AUGUST 1

Priority point totals will be emailed

AUGUST 28

Booth space applications open online

SEPTEMBER 27

Booth applications due including 50% deposit and company description (200 bonus priority points will be applied if full payment is submitted with application)

OCTOBER 18

Booth space selection appointment letters emailed

OCTOBER 25-NOVEMBER 13

Booth space assignments taking place, per scheduled phone appointment

NOVEMBER 20

Booth space confirmations emailed

DECEMBER 2

Affiliate functions applications available online in your exhibitor dashboard

December 2

Exhibitor Service Kit opens online

DECEMBER 2

Exhibitor badge registration opens online

DECEMBER 13

Final booth payments due

DECEMBER 17

Last day to cancel exhibit space without incurring a penalty

DECEMBER 18-JANUARY 17

Booth cancellation will forfeit 30% of total booth fee

JANUARY 18-MARCH 17

Booth cancellation will forfeit 50% of total booth fee

FEBRUARY 21

Company information updates to be made in your exhibitor dashboard for the Final Program. You are responsible for updating company information by this date.

MARCH 18

Booth cancellation on or after this date will forfeit 100% of total booth fee

MARCH 6

Housing cut-off. All reservation names must be submitted to onPeak by this date or rooms will be released

MARCH 17

Island booth blue prints with line drawings and hanging sign/rigging plans due to exhibits manager (ISLAND BOOTHS ONLY)

MARCH 17

Hazardous waste/wet lab forms due to exhibits manager

MARCH 17

EAC forms & EAC certificate of insurance forms* due to ASCRS Exhibits Manager jbarbera@ascrs.org

*If forms are not received by this date, you will be required to use Freeman for install and dismantle services.

MARCH 17

Laser Safety forms due for ASCRS and ASOA exhibit hall and Subspecialty Day & WCCVIII exhibits (if applicable for your exhibit)

APRIL 24

Mailing samples with pre-registration attendee list request form due. Attendee lists will not be processed after this date

May 1

Giveaway approval request deadline

MAY 13-18

Exhibitor registration open

MAY 13-15

ASCRS Exhibit hall installation

MAY 13

WCCVIII exhibit tables move in 1pm-5pm

MAY 14

ASCRS Subspecialty Day exhibit tables move in 1pm-5pm

HALL A - B, EXHIBIT LEVEL

Saturday, May 16	9:00 a.m.–6:00 p.m.
Sunday, May 17	9:00 a.m.–6:00 p.m.
Monday, May 18	9:00 a.m.–5:00 p.m.

ASCRS WELCOME PARTY

4:30–6:00 p.m. taking place in the exhibit hall on Saturday, May 16.

EXHIBITOR REGISTRATION, LEVEL 0, EAST REGISTRATION EXHIBIT LEVEL

Wednesday, May 13	8:00 a.m.–5:00 p.m.
Thursday, May 14	8:00 a.m.–6:00 p.m.
Friday, May 15	7:00 a.m.–7:00 p.m.
Saturday, May 16	7:00 a.m.–5:00 p.m.
Sunday, May 17	7:30 a.m.–5:00 p.m.
Monday, May 18	8:00 a.m.–12:00 p.m.

EXHIBITS INSTALLATION, HALLS A-B

Wednesday, May 13	8:00 a.m.–8:00 p.m.
Thursday, May 14	8:00 a.m.–8:00 p.m.
Friday, May 15	8:00 a.m.–5:00 p.m.

EXHIBITS DISMANTLE, HALLS A-B

Monday, May 18	5:00 p.m.–9:00 p.m.
Tuesday, May 19	8:00 a.m.–5:00 p.m.
Wednesday, May 20	8:00 a.m.–5:00 p.m.
Thursday, May 21	8:00 a.m.–12:00 p.m.

WORLD CORNEA CONGRESS VIII EXHIBITS MEETING ROOMS FOYER, LEVEL 2

INSTALLATION

Wednesday, May 13	1:00–5:00 p.m.
-------------------	----------------

EXHIBITS OPEN

Thursday, May 14 & Friday, May 15	7:00 a.m.–4:00 p.m.
-----------------------------------	---------------------

DISMANTLE

Friday, May 15	4:00–6:00 p.m.
----------------	----------------

ASCRS SUBSPECIALTY DAY EXHIBITS BALLROOM FOYER, LEVEL 3

INSTALLATION

Thursday, May 14 1:00–5:00 p.m.

EXHIBITS OPEN

Friday, May 15 7:00 a.m.–4:00 p.m.

DISMANTLE

Friday, May 15 4:00–6:00 p.m.

ASCRS EXHIBIT HALL DISMANTLE

EXHIBITS CLOSE:

Please keep the aisles clear of debris during the move out process to prevent trip hazards. Freeman will begin pulling aisle carpet promptly at 5:00 p.m. Please pull those parts of your displays you can easily handle and are closest to the aisles further into your booth space to help protect them.

EMPTY RETURN:

Freeman will begin the return of empty containers promptly at 5:00 p.m. on Monday for a projected completion of 12:00 a.m. Cardboard and fiber cases will be returned first. Please DO NOT offer gratuities to workers in an attempt to find your empties. To ensure your safety, exhibitors will not be allowed in the crate storage area.

Please schedule your staff and travel accordingly as we cannot guarantee what time you will be finished with teardown on Monday evening.

EXHIBITOR MOVE-OUT

May 18	5:00 p.m. - 9:00 p.m.
May 19	8:00 a.m. - 5:00 p.m.
May 20	8:00 a.m. - 5:00 p.m.

All labor and outbound material handling services performed after 4:30 p.m. will have overtime charges applied.

DISMANTLE INFORMATION

All exhibitor materials must be removed from the exhibit facility by 5:00 p.m. on Wednesday, May 20, 2020.

To ensure all exhibitor materials are removed from the exhibit facility by the Exhibitor Move-Out deadline, please have all carriers check in by 2:00 p.m. on Wednesday, May 20, 2020. Drivers not checked in by this time will risk the possibility of their shipments going out on the house carrier.

POST SHOW PAPERWORK AND CARRIER CHECK IN

FREEMAN Exhibitor Services Department will gladly prepare your outbound Material Handling Agreement and labels in advance. Complete the Outbound Shipping form in the service kit and your paperwork will be available at show site. Be sure your carrier knows the company name and booth number when making arrangements for shipping your exhibit at the close of the show.

EXHIBIT BOOTH SPACE ASSIGNMENT

The ASCRS exhibits are an extension of the continuing education program. To be accepted by ASCRS, the products and services should be related to the ophthalmic or medical administrative fields.

Booth placement is prioritized using a point system and assigned during a scheduled phone call between the exhibits manager and the designated booth contact for each exhibiting company. Companies with the greatest number of points are assigned first, progressing to companies with the fewest amount of points.

Points are accrued through a variety of opportunities extended by ASCRS. See next page for details.

Prior to booth assignments, exhibiting companies will be evaluated according to points earned. An email will be sent out to all exhibiting companies from the previous year detailing total points earned for the following year.

In order for an exhibiting company's accrued priority points to be applied to space selection standings, the exhibiting company must submit the completed space application to ASCRS by the published deadline.

The exhibit booth space application will be considered complete when it has been signed by the appropriate authorized personnel and the 50% deposit amount received by the published deadline date.

An additional 200 priority points will be allotted toward the 2020 Annual Meeting booth space selection standings if full payment is received with your exhibit space application by deadline.

Applications received on or after the deadline will be processed once space selection assignments have taken place. These booths will be assigned based on availability and priority points will not be considered.

CONFIGURATION OF EXHIBIT HALL

ASCRS reserves the right to reconfigure the exhibit hall floor plan and reassign any exhibiting company at any time. Should the affected exhibitor cancel their space as a result of their booth reassignment, space payments will be refunded in full. The affected exhibitor must submit their cancellation notification in writing no later than 5 days after notification of space reassignment to receive refund.

BOOTH SHARES

Companies wishing to share a booth space must have a minimum of 200 square feet.

Both companies are required to submit a separate booth space application and a signed letter on official company letterhead by each company acknowledging they agree to share the space.

Please send your applications to the exhibits manager, exhibits@ascrs.org or fax to (703) 547-8840.

Each company must provide individual company descriptions and product categories to be listed in annual meeting publications.

If companies are splitting the booth fee, please note this in the payment field.

Both companies will be listed in the programs and meeting app.

PRIORITY POINTS

Priority points are a large factor in your exhibit location at the ASCRS Annual Meeting.

ASCRS recognizes that the location of a booth at our Annual Meeting is of high strategic importance and has a system in place that determines the order of space selection and assignment for each exhibitor.

With the exception of the number of consecutive years exhibiting, priority points are accrued in the following ways and reset to zero after each year's Annual Meeting concludes. Priority points are not earned based upon booth size or cost of exhibition space.

WAYS TO EARN POINTS

1. Years exhibiting at consecutive annual meetings are accrued per year and applied to the next consecutive year.

- 1–5 consecutive years exhibiting are awarded 10 points per year
- 5–10 consecutive years exhibiting are awarded 20 points per year
- 10–15 consecutive years exhibiting are awarded 30 points per year
- 15–20 consecutive years exhibiting are awarded 40 points per year
- 20+ consecutive years exhibiting are awarded 50 points per year

2. Utilizing the ASCRS official housing bureau, onPeak, for 100% of the exhibiting company's housing needs.

- Ten (10) times the total square footage of your booth at the 2018 Annual Meeting will be awarded in points toward the 2019 Annual Meeting if onPeak is used.
 - If onPeak is not utilized from the 2019 Annual Meeting for the exhibiting company's housing needs, said company will lose priority points towards the 2020 Annual Meeting equal to 50% of the total booth square footage.
3. Exhibiting at 2019 ASCRS Subspecialty Day you will earn 25% of the total dollar spent towards the 2020 Annual Meeting.
4. Exhibiting at the Combined Ophthalmic Symposium and/or YES Advanced Cataract Training meetings during the 2018 calendar year will accrue 25% of the total dollar spent and applied toward the 2020 Annual Meeting.
5. Purchasing advertising and/or participating in sponsorship opportunities from the 2018 Annual Meetings or by contracting with ASCRS to host a corporate event during the 2018 calendar year will accrue 25% of the total dollar spent toward the 2020 Annual Meeting.
6. Donations to the ASCRS Foundation during the 2018 calendar year will accrue 25% of the total dollar donated in earned priority points toward the 2020 Annual Meeting.
7. An additional 200 priority points will be awarded to all exhibiting companies who submit full booth payment with their completed booth application by the August 31 deadline. These additional points will be considered toward the 2020 booth space assignment.

PRIORITY POINT ACCRUAL PERIODS

CATEGORY	ACCRUAL PERIOD	YEAR APPLIED
Years exhibiting at annual meeting	Past consecutive years	2020
Housing	Fulfillment of final block utilized at 2019 Annual Meeting	2020
Exhibiting at ASCRS Subspecialty Day	2019 Annual Meeting	2020
Advertising and marketing	Calendar year, January 2018–December 2018	2020
Exhibiting at the Combined Ophthalmic Symposium and/or YES Advanced Cataract Training	Calendar year, January 2018–December 2018	2020
ASCRS Foundation donation	Calendar year, January 2018–December 2018	2020
100% booth payment submitted at time of contract submission by deadline date	August 28, 2019 – September 27, 2019	2020

BOOTH SPACE FEES & PAYMENTS

EXHIBIT SPACE RENTAL FEES

Space rental fees are charged according to booth configuration and size.

All exhibit specifications will be in accordance with ASCRS's rules and regulations.

Inside Linear/Perimeter: \$3,800.00

Corner Linear/Perimeter: \$3,800.00

Linear booths are sold in ten-foot by ten-foot (10' x 10') increments. Island:

Island Booths: \$38.00 per square foot

An island booth is defined as a booth with all sides exposed to an aisle. To determine the cost multiply the size by \$38 (example: 20' x 20' = 400 x \$38 = \$15,200).

INCLUDED IN BOOTH FEE:

- Six complimentary exhibitor personnel badges per 100 square feet of booth space.
- Company listing in the ASCRS Program Preview, Online Real-Time Program, and Final Program if provided in your exhibitor dashboard.
- Show issue of EyeWorld: exhibiting company's name, product categories, and booth number.
- ASCRS meeting app.
- Admission to the ASCRS Welcome Party on Saturday at the convention center, the ASCRS Film Festival, the ASOA Celebration, as well as admission to ophthalmologist and administrator sessions, provided seating is available.

PAYMENT SCHEDULE

Each exhibiting company will be required to submit a deposit amount equaling 50% of the selected booth space fee with the completed application no later than September 27, 2019. Applications submitted without payment will not be binding and space will not be assigned or held

COMPANIES WHO DO NOT SUBMIT A CONTRACT BY SEPTEMBER 27 WILL NOT HAVE THEIR ACCRUED PRIORITY POINTS CONSIDERED TOWARD THE 2020 SPACE SELECTION AND WILL NOT BE ASSIGNED A BOOTH SPACE APPOINTMENT TIME UNTIL AFTER THE INITIAL ASSIGNMENTS ARE COMPLETED.

The remaining 50% balance is due December 13. Contracts submitted after this date must include the full booth space fee in order to be processed.

If payment is not received on or before December 13, exhibitors will lose 10 priority points (towards the following years' Annual Meeting booth space), per day, each day the balance is overdue.

ASCRS may cancel or reassign unpaid space without notification. Returned payments will be charged a processing fee of \$50.00.

BOOTH SPACE CANCELLATIONS

CANCELLATION POLICY

Cancellation of assigned booth space must be submitted in writing to the exhibits manager. Cancellations will not be taken on the phone.

Upon cancellation of exhibit space, exhibitor is responsible for canceling any hotel rooms and/or meeting space that may have been on hold.

Exhibitors canceling after booth space has been contracted will forfeit a percentage of the total space fee based on the following schedule:

- 150 days from show date (December 18, 2019)–120 days from show date (January 17, 2020) forfeit 30% of total booth fee
- 119 days from show date (January 18, 2020)–60 days from show date (March 17, 2020) forfeit 50% of total booth fee
- 59 days from show date (March 18, 2020)–0 days from show date forfeit 100% of total booth fee

Exhibitors that fail to agree to (pay) the cancellation fee will not be permitted to exhibit at future ASCRS meetings until the balance is paid in full.

PAYMENT METHODS

ASCRS accepts American Express, Discover Card, MasterCard, VISA, Checks, and wire transfers.

PAYING BY CHECK:

Checks are to be made out to the American Society of Cataract and Refractive Surgery.

Checks are to be drawn on U.S. bank accounts only.

Check payments must accompany a copy of your booth space application and may be mailed to:

ASCRS
Attn: Exhibits Manager 4000 Legato Road, Suite 700
Fairfax, VA 22033

WIRE TRANSFER:

THE TRANSACTION FEE MUST BE INCLUDED IN THE TOTAL WIRE AMOUNT INCLUDING THE BANK'S PROCESSING FEE.

ASCRS IS NOT RESPONSIBLE FOR THIS AMOUNT AND YOU WILL BE BILLED FOR THE BALANCE.

Please ask your banking institution for the transaction fee amount to include. Wire details will not be provided until completed booth space application has been submitted.

Please contact the exhibits manager for wire instructions.

OUTSTANDING BALANCES/PAYMENTS DUE

Companies that have an outstanding balance due from a previous meeting for booths or marketing purchases will not be permitted to exhibit until the balance is paid in full.

DOWNSIZE POLICY

Requests to downsize assigned booth space must be submitted in writing to the exhibits manager. Downsize requests will not be taken on the phone.

Exhibitors downsizing after their booth space has been assigned will forfeit a percentage of the total space fee based on the following schedule and will be subject to booth relocation:

Requests to downsize after your booth has been assigned (October 25-November 13) will forfeit 50% penalty on the original complete booth space fee.

All requests received to downsize after November 13 will result in an 80% penalty on the original booth space fee.

IMPORTANT NOTE:

Final payments are due on December 13, 2019. If payment is not received on or before this date, exhibiting company will lose 10 priority points, per day, (towards their 2020 booth space) each day the balance is overdue. Exhibit space contracts submitted after December 13 must include the entire booth space fee in order to be considered complete.

Contracts that are not filled out completely will not be processed. For a contract to be considered complete, it must include product category and description on the following page.

COMPANY NAME _____

ADDRESS 1 _____

ADDRESS 2 _____

CITY _____

STATE _____ ZIP _____

COUNTRY _____

COMPANY PHONE _____

COMPANY FAX _____

BUSINESS EMAIL _____

WEBSITE _____

BOOTH CONTACT INFORMATION (ASCRS ASOA USE ONLY) _____

BOOTH CONTACT NAME _____

BOOTH CONTACT TITLE _____

PHONE _____ EXT _____

EMAIL _____

BOOTH SIZE REQUEST:

Booth Type—Please place an “X” next to your preferred booth type. There is a 10’x10’ minimum for linear booth space and a 20’x20’ minimum for island booth space

_____ CORNER-LINEAR BOOTH \$3800 PER SQUARE FOOT

_____ INSIDE-LINEAR-PERIMETER BOOTH \$3800 PER SQUARE FOOT

_____ **IF YOU ARE REQUESTING AN INLINE BOOTH (10X10) PLEASE ALSO INDICATE THE QUANTITY NEEDED HERE. (EXAMPLE: 10X20 REQUESTS WOULD DESIGNATE A 2 IN THIS BOX.)**

_____ ISLAND BOOTH \$38 PER SQUARE FOOT

Please list below the companies you DO NOT want to be located near in the event you are unavailable for your booth space selection appointment call with ASCRS.

DO NOT PLACE ME NEAR THE FOLLOWING: _____

PAYMENT METHOD—PLEASE CHECK ONE.

VISA MasterCard AMEX Check Wire Transfer _____

(wire transfer fee must be included)

AMOUNT ENCLOSED \$ ACCOUNT NUMBER _____
EXPIRATION DATE _____ CODE _____

NAME OF CARDHOLDER _____

AUTHORIZATION: Contracts will not be processed without signature and a 50% deposit on booth space. I am an authorized representative of the company with full power and authorization to sign and deliver this application and contract. The company listed on this application agrees to comply with all the policies, rules and regulations contained in the Exhibitor Prospectus, and the policies, rules and regulations adopted after publication of the exhibitor guide.

AUTHORIZED NAME (PRINT) _____ DATE _____

AUTHORIZED SIGNATURE _____ TITLE _____

COMPANY LISTING INFORMATION (Please Type or Print)

Please provide a company description in 100 words or less for publication in the online floor plan listing. Company description should focus on the product and its usage. ASCRS reserves the right to edit text to format and fit requirements without notice. Once your contract has been submitted you will have the ability to log in to your exhibitor dashboard at any time and update your company description and categories if needed.

PRODUCT CATEGORY (Minimum of 1 must be selected, maximum of 6 permitted)

To ensure that we have your company listed under the appropriate product category, please circle up to 6 categories or types in the following listing. If there is not a description that best describes your company product, please enter this on the line below:

<input type="checkbox"/> Advertising Specialty	<input type="checkbox"/> Endoscopy Repair/Rebuild	<input type="checkbox"/> Measurement Equipment	<input type="checkbox"/> Refractive Systems
<input type="checkbox"/> A-scans	<input type="checkbox"/> Equipment Leasing	<input type="checkbox"/> Microkeratomes	<input type="checkbox"/> Regulators/Devices
<input type="checkbox"/> Calibration Equipment	<input type="checkbox"/> Exam Room Furniture/Equip	<input type="checkbox"/> Microscopes	<input type="checkbox"/> Research & Development
<input type="checkbox"/> Capsular Tension Rings	<input type="checkbox"/> Financial Services	<input type="checkbox"/> Office/ASC Design & Plan	<input type="checkbox"/> Resurfacing Equipment
<input type="checkbox"/> Certifying Agency	<input type="checkbox"/> Frames/Sunglasses	<input type="checkbox"/> Online Buying Group	<input type="checkbox"/> Retinal Implants
<input type="checkbox"/> Charitable Organization	<input type="checkbox"/> Glaucoma Pressure	<input type="checkbox"/> Ophthalmic Instruments	<input type="checkbox"/> Retinal Photography
<input type="checkbox"/> Communication Tech.	<input type="checkbox"/> Hand-Held Instrument	<input type="checkbox"/> Ophthalmic Surgery Table	<input type="checkbox"/> Solutions
<input type="checkbox"/> Computers	<input type="checkbox"/> Insurance Company	<input type="checkbox"/> Optical Supplies	<input type="checkbox"/> Sterile Supplies
<input type="checkbox"/> Computer Software	<input type="checkbox"/> Interior Planning	<input type="checkbox"/> Orbital Implants	<input type="checkbox"/> Sterilization Equipment
<input type="checkbox"/> Computer Systems	<input type="checkbox"/> Internet Services	<input type="checkbox"/> Outpatient Surgery Centers	<input type="checkbox"/> Surgery Ctr Development
<input type="checkbox"/> Corneal Masking	<input type="checkbox"/> Intracorneal Lenses	<input type="checkbox"/> Phacoemulsification Product	<input type="checkbox"/> Surgical Equipment
<input type="checkbox"/> Corneal Tissue	<input type="checkbox"/> Intraocular Lenses	<input type="checkbox"/> Pharmaceutical Products	<input type="checkbox"/> Surgical Instruments
<input type="checkbox"/> Corneal Topography System	<input type="checkbox"/> Lab Equipment	<input type="checkbox"/> Ophthalmologist Recruiting & Plcmt	<input type="checkbox"/> Surgical Stretchers
<input type="checkbox"/> Diagnostic Equipment	<input type="checkbox"/> Lacrimal Products	<input type="checkbox"/> Practice Management	<input type="checkbox"/> Surgical Supplies
<input type="checkbox"/> Digital Imaging Systems	<input type="checkbox"/> Laser/Laser Services	<input type="checkbox"/> PRK & LASIK Supplies	<input type="checkbox"/> Ultrasound Equipment
<input type="checkbox"/> Disposable Supplies	<input type="checkbox"/> Lens Services	<input type="checkbox"/> Product Development	<input type="checkbox"/> Video
<input type="checkbox"/> Education/Training	<input type="checkbox"/> Low Vision Products	<input type="checkbox"/> Protective Eye Guards	<input type="checkbox"/> Viscoelastics
<input type="checkbox"/> Electronic Medical Record	<input type="checkbox"/> Marketing	<input type="checkbox"/> Publication	<input type="checkbox"/> Web Site Design Services
<input type="checkbox"/> Other:			

To submit your booth space application, please ensure your contract is complete and mail or fax to the following:

Mail: Exhibits Manager
ASCRS
4000 Legato Road, Suite 700
Fairfax, VA 22033

Fax: (703) 547-8840
Attn: Exhibits Manager

Email: exhibits@ascrs.org

OFFICIAL HOTELS

The official housing management company for the ASCRS Annual Meeting is onPeak.

Housing opened at the 2019 ASCRS Annual Meeting in San Diego and is open to all exhibiting companies.

ONPEAK

Domestic Phone: (800) 370-8282

International Phone: (312) 527-7300

Email: ascrs-asoa@onpeak.com

ASCRS has contracted rooms for the 2020 Annual Meeting. These hotels are considered "official" hotels.

ANY HOTELS NOT LISTED HERE ARE NOT WITHIN THE ASCRS and ASOA BLOCK AND ARE NOT PROTECTED BY ONPEAK AND ASCRS.

PRIORITY POINTS FOR HOUSING

Exhibitors are required to secure all sleeping rooms through onPeak. In doing so, exhibitors have the ability to accrue or lose priority points.

Exhibitors that utilize onPeak for 100% of their housing needs receive ten (10) times their booth square feet in priority points toward the 2021 Annual Meeting. Exhibitors who do not utilize onPeak their housing needs will lose priority points for the 2021 Annual Meeting equal to 50% of their total booth square feet. Please see the Priority points section of the Exhibitor Guide for more details on how priority points are calculated.

SECURING HOUSING

In order to secure your exhibitor room(s) or block, you will need to submit your request online. This will notify onPeak of your requested housing needs and on which nights you will need them for your staff.

Any exhibitor requesting a room block of 20 rooms or more will be required to accept the terms of the ASCRS Attrition Agreement along with their online exhibitor room block request.

ASCRS reserves the right to make adjustments to your room block based on your organization's history of rooms reserved vs. rooms utilized. Any request for an increase in excess of 5% of your total room pick-up from the previous year will only be granted when extenuating circumstances exist; this is subject to approval by the exhibits manager.

The exhibitor room blocks will be limited at some locations.

A Maximum of 30 rooms can be booked at the following hotels:

- Westin Waterfront
- Renaissance Waterfront

For all other hotels, onPeak/ASCRS will try and accommodate each groups needs based on availability as best as possible. Your group may need to be split up between multiple hotels.

When requesting any type of suite, please note that it will count for more than one room hotel allotment.

A one-bedroom suite will count as two rooms and a two-bedroom suite will count as three rooms.

All requests for suites that will be used as sleeping rooms must go through onPeak.

Hospitality suite requests for the purpose of meetings or entertaining must be submitted through the affiliate function process. Guidelines on requesting meeting space will be published in November. Please contact the Exhibits Manager for details, exhibits@ascrs.org if you have any questions

ROOM ASSIGNMENT AND CONFIRMATION

All housing assignments will be made in the order they are received. If your hotel choices are not available, an assignment will be made in a hotel comparable to your requested choices.

ONPEAK WILL SEND YOU A CONFIRMATION OF YOUR HOTEL ASSIGNMENT AFTER THE CUT OFF TIME PERIOD.

You will be able to distinguish email communications from onPeak, the official housing management company, as they will have the 2020 ASCRS official meeting logo within the communication and official onPeak seal.

There are many companies that try to pose as the official ASCRS housing management company. Please contact ASCRS directly if you are uncertain of the designation of a company that has been contacting you.

ROOMING LISTS:

Exhibitor group block rooming lists are due to onPeak by March 6, 2020.

ASCRS | ASOA
ANNUAL MEETING

15-19 MAY 2020 | BOSTON, MA

HOTELS	Distance to BCEC	Rates single/double
1. Aloft Boston Seaport District	1 block	\$285
2. Boston Marriott Copley Place	2.2 miles	\$329
3. Boston Park Plaza	1.6 miles	\$299
4. Courtyard Boston Downtown	1.6 miles	\$315 / \$335
5. DoubleTree by Hilton Boston Downtown	1.5 miles	\$315
6. Element Boston Seaport District	1 block	\$285
7. Four Seasons Boston	1.5 miles	\$545
8. Godfrey Hotel Boston	1.1 miles	\$334
9. Hilton Boston Back Bay	2.4 miles	\$323 / \$333
10. Hilton Boston Logan Airport	3.1 miles	\$276 / \$286
11. Hyatt Regency Boston	1.0 mile	\$333
12. InterContinental Boston	.8 mile	\$399
13. Omni Parker House	1.2 miles	\$299
14. Renaissance Boston Waterfront	.3 mile	\$349
15. Revere Hotel Boston Common	1.6 miles	\$329
16. Ritz-Carlton Boston	1.2 miles	\$525
17. Seaport Hotel	.2 mile	\$349
18. Sheraton Boston	2.4 miles	\$303
19. W Boston	1.5 miles	\$368
20. Westin Boston Waterfront	connected	\$315
21. Westin Copley Place	2.1 miles	\$328
22. Yotel Boston	.5 mile	\$275

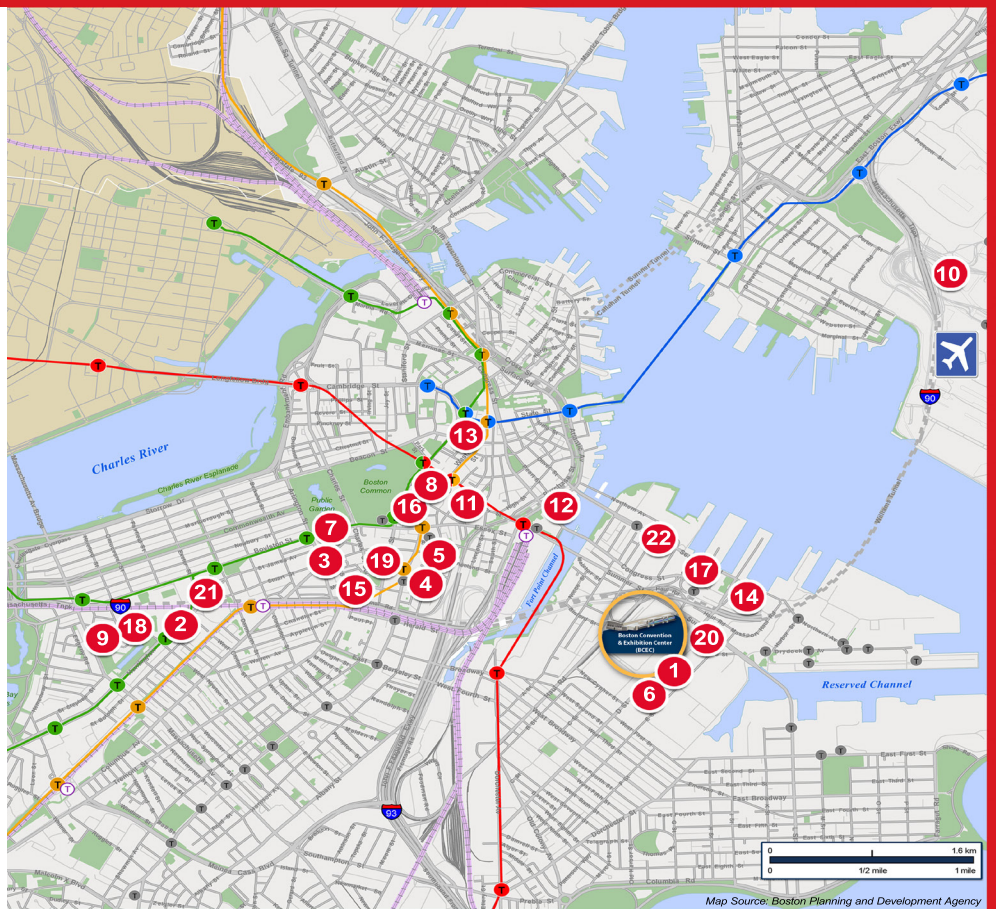

Map Source: Boston Planning and Development Agency

1. Aloft Boston Seaport District	1 block	\$285
2. Boston Marriott Copley Place	2.2 miles	\$329
3. Boston Park Plaza	1.6 miles	\$299
4. Courtyard Boston Downtown	1.6 miles	\$315 / \$335
5. DoubleTree by Hilton Boston Downtown	1.5 miles	\$315
6. Element Boston Seaport District	1 block	\$285
7. Four Seasons Boston	1.5 miles	\$545
8. Godfrey Hotel Boston	1.1 miles	\$334
9. Hilton Boston Back Bay	2.4 miles	\$323 / \$333
10. Hilton Boston Logan Airport	3.1 miles	\$276 / \$286
11. Hyatt Regency Boston	1.0 mile	\$333
12. Intercontinental Boston	.8 mile	\$399
13. Omni Parker House	1.2 miles	\$299
14. Renaissance Boston Waterfront	.3 mile	\$349
15. Revere Hotel Boston Common	1.6 miles	\$329
16. Ritz-Carlton Boston	1.2 miles	\$525
17. Seaport Hotel	.2 mile	\$349
18. Sheraton Boston	2.4 miles	\$303
19. W Boston	1.5 miles	\$368
20. Westin Boston Waterfront	connected	\$315
21. Westin Copley Place	2.1 miles	\$328
22. Yotel Boston	.5 mile	\$275

AFFILIATE FUNCTION POLICIES & PROCEDURES

REQUESTING MEETING SPACE

Companies must complete the meeting space application, available online only, for any industry hosted events, and gain ASCRS approval prior to contacting or working with the selected hotel or venue.

Applications will open December 2, 2019

THE APPLICATION MUST BE COMPLETED FOR EVERY AFFILIATE FUNCTION, PER DAY FUNCTION SPACE IS NEEDED AND WHETHER OR NOT THE MEETING IS AT ONE OF THE ASCRS OFFICIAL HOTELS.

If you are requesting function space at a location that is not listed in the menu selection, you are still required to apply for function space through the online application process and note the requested location.

The meeting space application can be found within your exhibitor dashboard starting December 2, 2019. Requests can only be made online. Payment will be due at time of submitting your application otherwise the request will not be sent through the database. All space assignments are subject to availability and requests are handled on a first-come, first-served basis.

Hospitality Suites fall under the affiliate function policy and follow all rules and regulations set forth by the affiliate function policy and procedures listed here.

CONFIRMED EXHIBITORS:

A non-refundable \$250.00 administrative fee will be required at time of application per function, per day up until February 1, 2020. Space requests made on or after February 2, 2020 will be charged a non-refundable \$500.00 administrative fee.

NON-EXHIBITING COMPANIES:

A non-refundable \$1000.00 administrative fee will be required at time of application per function, per day.

Payments must be made at time of application using one of the following credit cards at the time of application: American Express, Discover Card, MasterCard or VISA.

CHECKS WILL NOT BE ACCEPTED AS A FORM OF PAYMENT FOR AFFILIATE FUNCTIONS.

POLICIES AND PROCEDURES

ASCRS does not endorse or sanction any affiliated function. Use of the ASCRS and its subsidiaries' names or logos in conjunction with these events is strictly prohibited.

ASCRS will not be held responsible for any charges incurred by approved or outside vendors. All charges are the sole responsibility of the company hosting the affiliate event.

ASCRS MEETING SPACE APPROVAL PROCESS

All functions must be scheduled so as not to interfere with the ASCRS, ASOA and EyeWorld program, breaks, events, and lunches.

Events that are submitted that conflict with the below outlined dates and times will not be approved.

CORPORATE AFFILIATE MEETINGS

Corporate affiliate meetings are defined as functions that include only the exhibiting company personnel.

1. These meetings may be scheduled anytime from Thursday, May 14–Monday, May 18 providing meeting space is available at the requested location.
2. All Corporate Affiliate Meetings must be submitted to ASCRS through the meeting space application process and must be approved by ASCRS.

AFFILIATE MEETINGS WITH 100 AND FEWER PROFESSIONAL ATTENDEES

A professional attendee is defined as an ophthalmologist, optometrist, practice administrator, technician or nurse, and/or anyone considered to be a health professional.

1. Affiliate meetings and functions that include the attendance of less than 100 professional attendees may be held beginning Thursday, May 14–Monday, May 18 within the following time periods (please note there is limited availability):

Thursday, May 14	Any time
Friday, May 15	Prior to 8:00 a.m. & after 5:30 p.m.
Saturday, May 16	Prior to 8:00 a.m. & after 5:30 p.m.
Sunday, May 17	Prior to 8:00 a.m. & after 5:30 p.m.
Monday, May 18	Prior to 8:00 a.m. & after 5:30 p.m.

- The above time periods reflect when any aspect of the event may begin including registration and reception.
- All affiliate meetings with 100 and fewer professional attendees must be submitted to ASCRS through the meeting space application process and must be approved by ASCRS.

AFFILIATE MEETINGS WITH MORE THAN 100 PROFESSIONAL ATTENDEES

A professional attendee is defined as an ophthalmologist, optometrist, practice administrator, technician or nurse, and/or anyone considered to be a health professional.

- Affiliate meetings and functions that include the attendance of more than 100 professional attendees may be held beginning Thursday, May 14–Monday, May 18 within the following time periods (please note there is limited availability):

Thursday, May 14	Any time
Friday, May 15	Prior to 7:00 a.m. & after 7:00 p.m.
Saturday, May 16	Prior to 7:00 a.m. & after 7:00 p.m.
Sunday, May 17	Prior to 7:00 a.m. & after 7:00 p.m.
Monday, May 18	Prior to 7:00 a.m. & after 7:00 p.m.

- The above time periods reflect when any aspect of the event may begin including registration and reception.
- All affiliate meetings with more than 100 professional attendees must be submitted to ASCRS through the meeting space application process and must be approved by ASCRS.

3rd PARTY COORDINATOR INFORMATION

Companies using a third party to coordinate their off-site events, are required to have their contact information included in the online application.

POLICY REGARDING UNAPPROVED FUNCTIONS

In order to maintain the integrity of the meeting for all attendees and exhibitors, the following enforcement policy will be enacted for all affiliate meetings. ASCRS will speak with the hotel/venue, company contact listed on the application or other personnel with managerial responsibility and require that the affiliate function be shut down during show hours for all violations.

1ST OFFENSE

The exhibiting company hosting the function will have their priority points accrued during the current year reduced by 50%. They may also be prohibited from requesting meeting space for the following year. In addition, the exhibitor will not receive any priority points accrued for either the housing or the consecutive years attending.

2ND OFFENSE

The exhibiting company hosting the function will lose all priority points accrued during the calendar year, and will receive no priority points for the remaining portion of the year. ASCRS will not permit the company to host or act as a meeting planner for any affiliate function for the following two years. Additionally, the company may be prevented from exhibiting or attending the following ASCRS Annual Meeting.

3RD OFFENSE

ASCRS will prohibit the exhibiting company hosting the function from exhibiting at the next ASCRS meeting. The exhibitor will lose all priority points accrued during the calendar year, and will receive no priority points for the remaining portion of the year. ASCRS will not permit the company to host or act as a meeting planner for affiliate function the following five consecutive years.

ASCRS appreciates the need for each firm to conduct business in an effective and efficient manner during the course of the meeting and are pleased to note that the large majority of exhibitors comply with our policies, enabling our attendees to enjoy the full scope of educational and social content offered by both ASCRS and our industry partners.

BEFORE THE EXHIBITION

BIOMEDICAL WASTE

Companies with exhibits that include the use of animal tissue, human tissue, disposable needles, sharps, human blood, or products contaminated with blood must complete the ASCRS liability waiver and the hazardous waste removal order form and pay the corresponding fee for removal of the waste, no later than March 17, 2020.

Additional information including the liability waiver and hazardous waste removal order form can be found in the Exhibitor Service Kit available online in December.

BIOMEDICAL HAZARDOUS WASTE (SUPPLIES & REMOVAL)

Companies with exhibits that include the use of animal tissue, human tissue, disposable needles, sharps, human blood, or products contaminated with blood must complete the ASCRS liability waiver, the hazardous waste removal order form and pay a fee for the removal of the waste. A Freeman representative will pick up the medical waste every evening from your booth. More information can be found in the service kit available in December.

LASERS & OTHER POTENTIALLY HAZARDOUS LIGHT SOURCES

Any exhibitor who will be utilizing or displaying lasers (inoperable or operable) or other hazardous optical sources will be required to review the ASCRS Laser Safety Guidelines and submit the laser safety use form to the exhibits manager no later than March 17, 2020. This form will be in the Exhibitor Service Kit available in December.

LASER SAFETY INSPECTIONS & REGISTRATION

The exhibiting company utilizing or displaying lasers during the ASCRS exhibit hall and Subspecialty Day will be subject to a laser safety inspection performed by an outside expert along with an ASCRS staff member. A schedule will be provided before move in begins onsite.

Absolutely no lasers will be displayed without first being inspected and approved by the laser safety inspector. Identification signs stating the class of laser, inoperable or not FDA approved at this time, are required to be displayed for such lasers. Signage must be displayed at all times during the show or equipment housing the laser will be removed immediately, at the expense of the exhibitor.

Exhibitors with lasers may also be subject to, without notice, an inspection by The Massachusetts Department of Health. Should the state feel that the laser(s) do not meet approval, the exhibitor will not be permitted to use the laser(s) during the show.

You are required by the state of Massachusetts to register your laser(s). The registration form will be available in the Exhibitor Service Kit in December.

FLAMMABLE & TOXIC MATERIALS

All materials used in display, construction or decorating should be made of fire retardant materials and be certified as flame retardant.

Samples are required to be available for testing preshow and onsite. Materials that cannot be treated to meet the requirements are not permitted for use. A flame-proof certificate is required to be available on hand for inspection.

Flame retardant certificates must be sent to the exhibits manager by March 17, 2020.

Exhibitors should be aware of local regulations regarding fire/ safety and environment which must be adhered to.

All gas cylinders must be securely fastened to a carriage or to a fixed location at all times, and may be subject to fire marshal review

Exhibitors should dispose of any waste products they generate during the exhibition in accordance with guidelines established by the Environmental Protection Agency and the facility.

All hazardous waste will be retrieved from your booth each evening by Freeman.

Please contact the exhibits manager for further explanation and detail.

SPECIALTY GASES

If you will need to order specialty gases, please contact:

Messer Industrial Gases

1-833-7MESSER

Electronics.cs@messer-us.com

FDA REGULATIONS

Exhibitors must abide by all applicable Food and Drug Administration (FDA) regulations, including but not limited to any or all approval requirements. Exhibitors are reminded that the FDA generally prohibits the advertising or other promotion of investigational or unapproved drugs and devices. The FDA also forbids the commercial promotion of approved drugs or devices for unapproved uses.

Unapproved devices may be displayed only if they are the subject of an effective investigational device exemption (IDE) or if they are the subject of a pending 510(k) pre-market notification application. Exhibitor is required to post a sign stating the device or product is not FDA Approved at this time.

Any investigational product that is displayed or graphically depicted within the exhibit must (a) contain no claims of safety or effectiveness, (b) contain no comparative claims to other marketed products, and (c) be accompanied by a sign clearly and prominently stating that the device is limited by federal law to investigational use and is not approved by the FDA for commercial distribution in the United States.

Exhibitors may not sell, commercialize, or take orders or names with respect to an investigational drug or device, or a device that is subject of a pending 510(k) application, unless limited to research or investigational use.

These restrictions are not intended to limit the full exchange of scientific information regarding an investigational drug or device. If the FDA or a court of competent jurisdiction determines that a company's exhibit at an ASCRS meeting is in violation of any FDA regulations, including but not limited to the promotional restrictions and rules described above, the company may be subject to sanctions, including but not limited to exclusion from exhibiting at subsequent ASCRS meetings.

Concerns or questions regarding compliance with FDA regulations should be addressed to the appropriate agency within the FDA.

EXHIBITOR APPOINTED CONTRACTORS (EAC) & LABOR

Labor within the booth can be provided either through an exhibitor appointed contractor (EAC) you have hired or the official service contractor (Freeman). All individuals working in the hall must be badged at all times.

An EAC is any company other than one of the designated official contractors for ASCRS that provides services to an exhibitor and will require access to the show during installation, show days, or dismantle.

EACs are NOT permitted to perform any of the following services:

- Rigging/Hanging Signs
- Material Handling
- Electrical Services
- Catering
- Telecommunications/Internet
- Plumbing

DESIGNATING AN EAC

An exhibitor can designate an EAC for installation and dismantle of their booth, audio visual (A/V), photography, lead retrieval, or other specialty services, but the exhibiting company MUST submit the EAC authorization form and EAC insurance certificate to ASCRS by March 17, 2020 or the EAC will not be permitted access to the exhibit hall.

Documents may be submitted via email or fax to the contact below:

ASCRS Exhibits Manager
Exhibits Manager | exhibits@ascrs.org |
Fax: (703) 547-8840

Failure to submit forms by the designated deadline will result in the exhibiting company being required to use labor provided by the official service contractor for installation and dismantle and other ASCRS selected contractors for other services.

Exhibitor is required to submit a form for an EAC company that is not listed below:

- Freeman – Official Show Contractor & Audio Visual
- Itrisco Productions – Booth Photography/Video
- RA Consulting – Booth Security Services
- Urban Jungle, Inc. – Floral/Plant Services
- BCEC – Catering, Internet, Telecom, Rigging
- Xpress Leads Convention Data Services – Lead Retrieval

EAC ACCESS TO THE SHOW FLOOR

EACs are not permitted on the show floor during show hours. Should access to the show floor be necessary during show hours, the exhibiting company must allocate the EAC a badge from their corporate allotment of exhibitor badges and proper professional attire is required.

EAC CERTIFICATE OF INSURANCE (COI)

Exhibitors are not required to submit a COI. This is for EAC companies only. The EAC must send ASCRS an acceptable public liability insurance policy (COI) as to coverage limits

located on our meeting website and agree to name ASCRS, Freeman and the BCEC as an additional insured on any such policy(ies) and agree to furnish ASCRS proof of payment of the premium on any such policy(ies).

Policy(ies) shall expressly provide that the policy(ies) shall not be canceled or altered without at least 10 days prior written notice to ASCRS from the insurance company.

The COI must state Freeman as the certificate holder, be addressed to the location below and include the exhibiting company's name and booth number in the comments. See below for address:

Freeman | 275 Bodwell Street | Avon | MA | 02322

Exhibitor expressly agrees to indemnify and hold harmless ASCRS, its management, agents, and employees from any and all liability, claims, loss, damages or expenses, including counsel fees and costs resulting from injuries to any person, including other exhibitors, the agents, employees and attendees, or damage to any property, including property owned by other exhibitors, in connection with its use of the exhibit space.

Exhibitor agrees that the exhibition assumes no responsibility for the safety of the properties of the exhibitor, its officers, agents or employees from theft, damage by fire, accident or any other cause whatsoever.

The exhibition provides security guards for public spaces; however, attention is called to the necessity for insurance covering all risks (liability, fire, theft, damage, etc.) on your exhibit from place of shipment to the exhibition, facility, return, and during exhibition.

COIs may be submitted via email or fax to the contact below no later than March 17, 2020.

Exhibits Manager | exhibits@ascrs.org |
Fax: (703) 547-8840

EAC & LABOR BADGING

The BCEC uses the ESCA badging system. **All labor and EACs must check in at the service entrance and present their ESCA badge to gain access to the building and exhibit hall. If labor does not have an ESCA badge, they can obtain a sticker each day by showing proper photo ID.** Show management security and BCEC public safety officers will stop anyone not badged correctly and ask them to vacate the premises.

Wristbands will be given to EACs and Labor at the designated check in desk, during move-in and move-out and will only be given to EACs if ASCRS has received notice of intent to use an EAC along with a valid certificate of insurance (COI) from the EAC.

Wristbands allow EACs access to the show floor during move-in and move-out only. An EAC without the EAC work authorization form or without a valid certificate of insurance (COI) on file must provide completed documentation or will NOT be permitted on the show floor.

CONVENTION CENTER RULES/INSURANCE

Exhibitor expressly agrees to adhere to all convention rules and regulations published by the convention center. Exhibitor agrees to meet all convention center insurance requirements and accepts sole responsibility for securing required license/permits needed, for example, from ASCAP/BMI for the use of music in booth area. Please refer to the specific convention center website for further details.

UNION REGULATIONS

The BCEC has a jurisdictional agreement with its union labor partners; International Brotherhood of Electrical Workers and the International Brotherhood of Teamsters to perform specific work at the convention center. This includes the activities of move-in, installation, dismantling and move-out of trade shows, conventions, exhibits, corporate events and theatrical events.

LABOR RATES

Display union labor rates for installing & dismantling exhibits:

ST	\$133.29
OT	\$230.71

TEAMSTERS UNION – SEE BOSTON UNION GUIDELINES

Union jurisdictions prevail over all set-up and dismantling of exhibits including signs and laying of carpet. This does not apply to the unpacking and placement of your merchandise.

Any installation of exhibits or displays that requires the use of hand tools, more than one person, or longer than thirty minutes (including crating and uncrating) to install, or exceeds ten feet in any direction, shall be installed by employees covered by this agreement. One full-time company employee may supervise work with the union crew.

ELECTRICIANS UNION

BCEC is the contractor responsible for supervision, assembly and removal of all electrical needs, truss assemblies for lighting, audio-visual equipment and special effects, whether hanging or floor standing.

All power, electrical labor orders, and additional requirements for such equipment must be placed through the BCEC electricians. Your representative may be present during the assembly or the installation/ removal of your truss or lighting.

NOTE: The BCEC provides the electrical service only. Labor to run power cords under carpet is provided by Freeman or exhibitor's EAC. A Freeman Cord Labor order form is included in the Exhibitor Service Manual

MATERIAL HANDLING UNION JURISDICTIONS & EXHIBITOR PERSONNEL – SEE BOSTON UNION GUIDELINES

Union jurisdictions prevail over the operation of all material handling equipment, all unloading and reloading, and handling of empty containers.

An exhibitor may move material that can be hand-carried by one person in one trip without the use of dollies, hand trucks, or other mechanical equipment. Exhibitor personnel may perform the following functions as long as they are a full-time employee of the exhibiting company:

- Hand-carry small items and pop-up displays. No hand trucks or carts are permitted.
- Install and dismantle displays within a 100 square foot or less booth space if one person can accomplish the task in 30 minutes or less without the use of tools.
- Install graphics and small signs, and logos and graphics that are attached with pre-cut Velcro strips.
- Make technical electrical adjustments such as install light bulbs; plug in extension cords, etc.

EXHIBITOR HAND-CARRY PROCEDURES - SEE BOSTON UNION GUIDELINES

Exhibitors may transport materials they can carry in one trip to their booths. Examples of acceptable hand-carry materials include boxes, suitcases or fiberboard shipping cartons, portable displays on wheels and small luggage racks.

The following items are NOT considered hand-carry items: Two-wheel dolly loads, hotel bellman's carts, boxes or crates requiring two people to carry.

- Install and dismantle displays within a 100 square foot or less booth space if one person can accomplish the task in 30 minutes or less without the use of tools.
- Install graphics and small signs, and logos and graphics that are attached with pre-cut Velcro strips.
- Make technical electrical adjustments such as install light bulbs; plug in extension cords, etc.

GRATUITIES

Work rules prohibit the SOLICITATION OR ACCEPTANCE of tips in cash, products or gifts in kind by any employee (union or non-union). Our employees are paid appropriate wages denoting professional status, therefore tipping of any kind is not allowed.

PLUMBERS

The BCEC will handle all plumbing work such as compressed air, water, drain or natural gas.

RIGGING

JCalPro is the designated official providers of all rigging in the exhibit hall.

UNFINISHED SIDEWALLS & BACKWALLS

Exhibitors must mask all displays with unsightly back/side walls. If necessary, a drape will be installed to cover any unfinished parts of a display and the exhibitor will be charged accordingly by Freeman.

Material handling is the unloading of your shipment, transporting it to your booth, storing and returning your empty crates and cartons and reloading your shipment at the close of the show (also called drayage). This service is not included in the cost of your booth space. Avoid unexpected costs at show site and pre-order this service.

Handling charges are based on the weight of the freight. Shipments are billed by the hundred. A 200 lb minimum per shipment applies.

Minimum per shipment may apply, see Material Handling/ Drayage for details in the Exhibitor Service Kit. Please prepay all shipping charges - Freeman cannot accept or be responsible for collect shipments. Crated and uncrated shipments must be separated and clearly identified on separate bills of lading with separate weight tickets - otherwise Freeman will invoice the entire load at the uncrated rate.

- Crated - Material that is skidded or is in any type of shipping container that can be unloaded at the dock with no additional handling required.
- Uncrated - Material that is shipped loose or pad-wrapped, and/or unskidded machinery without proper lifting bars or hooks.
- Special Handling - Defined as shipments that are loaded by cubic space and/or packed in such a manner as to require special handling, such as ground loading, side door loading, constricted space loading and designated piece loading or stacked shipments. Also included are mixed shipments and shipments without proper delivery receipts.*
- Overtime Surcharges - Shows that move-in or move-out on weekends or after 5:00 p.m. during the weekday, may be subject to additional overtime surcharges.

WAREHOUSE SHIPMENTS – ST/ST

Boxed, crated or skidded	\$123.17/CWT
Special Handling*	\$165.94/CWT

SHOW SITE – ST/ST

Boxed, crated or skidded	\$128.70/CWT
Special Handling*	\$173.86/CWT
Uncrated	\$193.05/CWT

SHIPPING ADDRESSES

Shipping labels will be included in the Exhibitor Service Kit.

Advance Shipping — Freeman Warehouse:

ASCRS Annual Meeting
(your company name and booth number)
c/o Freeman
25 Doherty Ave
Avon, MA 02322 USA

Shipments should arrive between April 10, 2020 – May 4, 2020, Hours for receiving are Monday - Friday from 8:00 a.m.-3:00 p.m.

Drivers must be checked in by 2:00 p.m. to be guaranteed same day unloading

Freeman will accept crated, boxed or skidded materials beginning Friday, April 10, 2020, at the above address. Material arriving after Monday, May 4, 2020 will be received at the warehouse with an additional after deadline charge. Please note that the Freeman Warehouse does not accept uncrated freight (loose, pad-wrapped material and/or unskidded machinery), COD shipments, hazardous materials, freight requiring refrigerated or frozen storage, a single piece of freight weighing more than 5,000 pounds or a single piece of freight beyond the dimensions of 108" H x 93" W. Warehouse materials are accepted at the warehouse Monday through Friday between the hours of 8:00 a.m. - 3:30 p.m.

Direct Shipments to Show Site:

ASCRS Annual Meeting
(your company name and booth number)
c/o Freeman
Boston Convention & Exhibition Center
415 Summer Street
Cypher Street Entrance
Boston, MA 02210

The freight target floor plan for move in dates and times, will be available in December in the Exhibitor Service Kit.

You are required to adhere to the target floor plan schedule in order to assist with a smooth move-in for all exhibitors.

We have provided these definitions to acquaint you with specific guidelines for labor. If you have any questions once you have read this, please address them to Show Management or to Freeman directly.

The unpacking, erection, assembling, dismantling, and packing of displays and equipment may be done by full-time employees of an exhibiting company. The official labor contractor for the exposition will have skilled craftsmen to assist exhibitors who wish to hire labor to perform these services. Arrangements for all temporary labor should be made through the official service contractor. Official labor order forms are included in the exhibitor service manual.

MATERIAL HANDLING

Work rules require that the official material handling contractor off-load all equipment and display material from commercial carriers/common carriers or van lines. The use of fork trucks, pallet jacks and lift gates are permitted only by personnel of the official material handling contractor. Exhibitors are allowed to perform their own material handling, provided they meet all of the following criteria:

Personnel performing the work must be bonafide, full-time company employees of the exhibiting company.

They must be off-loading from a company owned truck or rental vehicle, or from a car, van or truck owned by personnel of the exhibiting company. All trucks, including co-owned or rental vehicles, over 24' in length will be off-loaded or loaded by the official material handling contractor.

They may use only hand-operated equipment, which they have provided; two-wheeled hand trucks and four-wheeled flat trucks are permitted. The use of fork trucks, pallet jacks, lift gates or any other mechanical equipment is not permitted by anyone other than the official drayage contractor.

BOOTH LABOR

BOOTH LABOR

Exhibitors are allowed to set-up and/or dismantle their own booths, provided that they use their own bonafide, full-time employees. Please advise them not to bring outside labor of any kind.

TIPPING

Our Work Rules prohibit the SOLICITATION of tips by any of our employees. Our employees are paid excellent wages denoting a professional status and we feel that tipping is not necessary. Should you be SOLICITED for a tip, please report the incident to our Service Center as soon as possible.

BOOTH SPACE DESIGN GUIDELINES

ASCRS invites exhibitors to create booth designs that are welcoming and engaging, however adoption of the ASCRS show look is prohibited.

Exhibits must conform to the professional and scientific atmosphere of the meeting and are subject to onsite review and, where necessary, modification at the exhibitor's expense.

All components of the booth design, including truss and lighting are to remain within the boundaries of the exhibit space.

All booths must have a floor covering. The full square footage of your exhibit booth space must be covered by 3:00 p.m. on Friday, May 15. Booths not containing floor covering will be supplied standard carpet and the exhibitor will be charged accordingly by Freeman.

No exhibitor shall assign/sublet any part of its assigned space without the written consent of ASCRS.

LINEAR BOOTHS

ASCRS does not permit Peninsula or End Cap Booths.

- Each ten-foot by ten-foot (10' x 10') linear booth has a back-wall drape at a uniform eight-foot (8') height and black side drape at a three-foot (4') height.
- The maximum allowable height of products and display materials is eight feet (8').
- Display materials greater than four feet (4') in height must be a minimum of five feet (5') back from the front aisle.
- Exhibitors must mask all displays with unsightly back or side walls.
- If necessary, a drape will be installed to cover any unfinished parts of a display and the exhibitor will be charged accordingly by Freeman.
- Linear booths are not permitted to have any gobos.

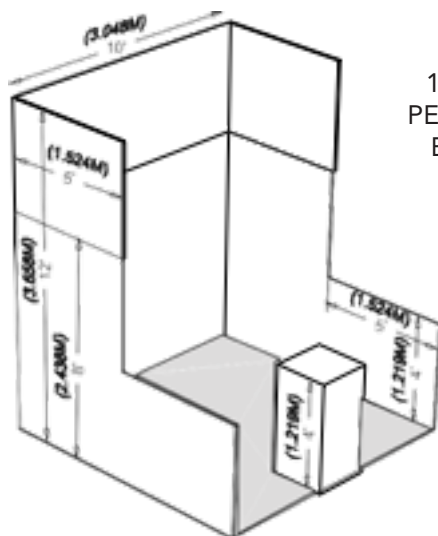

10' X 10'
PERIMETER
BOOTH

ISLAND BOOTHS

An island exhibit is an open area of exhibit space with aisles on all four sides. Island booths must be designed to allow access from all four aisles.

- Ceiling covering or floor covering may not span an aisle.
- Structures may not exceed twenty-five feet (25') in height.
- Theater seating for, presentations and demonstration areas in a booth are required to be a minimum of five-feet (5') back from the aisles and aisles must remain free from congestion.
- Exhibit displays, construction and signage must be arranged to allow for see-through visibility and must not obstruct a significant amount of the line of sight view or otherwise interfere with, the displays of other exhibitors.
- Conference, office, storage, or meeting room enclosures may not exceed 100 square feet in booths less than 1,600 square feet and must be constructed of building materials that allow see-through visibility or light penetration.

Please review further guidelines on the next page concerning island booth designs.

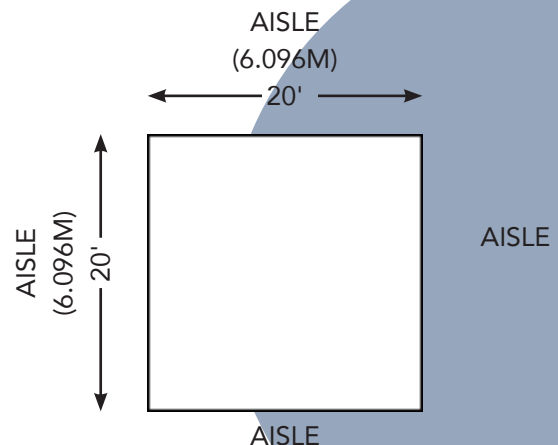
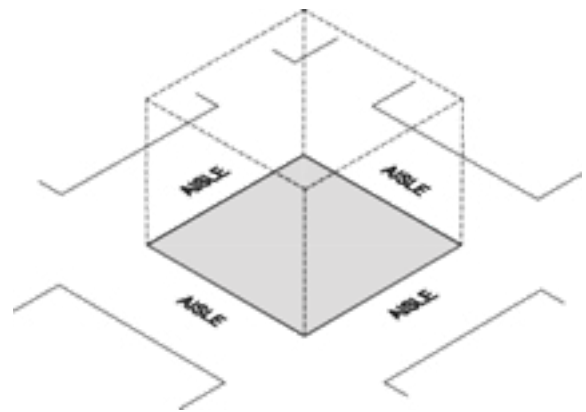

HANGING SIGNS

A hanging sign is defined as an exhibit component suspended above an island space exhibit for the purpose of displaying graphics or identification.

Hanging signs, regardless of type, are subject to the maximum size allowances stated in these policies and must conform to the standards that follow.

If the sign is hung horizontal or vertical, the combined length of all signs may not exceed the following limits:

(Multiple sign dimensions are totaled to determine the length of the sign)

- Hanging signs or banners are permitted in island booths only.
- Hanging signs and graphics will be permitted to a maximum height of 25 feet from the top of the sign to the floor, where applicable.
- For a single-faced or double-faced one-piece sign, the length of the sign may not exceed fifty percent (50%) of the booth dimension on the aisle that it faces.
- For a rectangular, square, circular, or triangular sign, the length of any side of the sign may not exceed fifty percent (50%) of the booth dimension on the aisle that it faces.
- The height limit for each side of a sign is eight feet (8').

CANOPIES, CEILINGS, TOWERS, AND MULTI-LEVEL EXHIBITS

Canopies and Ceilings: A canopy is defined as an exhibit component supported over an exhibitor's assigned booth space for decorative or functional purposes.

- Canopies, false ceilings, umbrellas and canopy frames will comply with all line-of-sight requirements.
- Canopies may not be lower than 7 ft. from the floor and within 5 ft. of any aisle.

Towers: A tower is defined as a free-standing exhibit component separate from the main exhibit feature. All towers are subject to the line-of-sight restrictions applicable to the type of exhibit space configuration being used.

Multi-Level Exhibit: A multi-level exhibit is defined as an exhibit booth where the display feature includes two levels. Multi-Level booths may not exceed two levels.

Additional information will be included in the online Exhibitor Service Kit.

BLUE PRINTS & BOOTH RENDERINGS

You are required to secure approval from the exhibits manager before beginning any new construction. If you are planning a new booth design, please send the preliminary blue prints to the exhibits manager and indicate the date by which approval is needed in order to meet your internal construction schedules.

Island booths are required to email a copy of blue prints indicating all dimensions as well as an isometric or elevation view of your exhibit including the hanging sign to the exhibits manager, jbarbera@ascrs.org, by March 17, 2020.

YOUR BOOTH LAYOUT AND HANGING SIGN ARE NOT CONSIDERED FINAL UNTIL THE EXHIBITS MANAGER HAS SENT YOU APPROVAL.

DURING THE EXHIBITION

ACCESS TO EXHIBITS

Exhibitors will have access to the hall prior to opening each day in accordance with the below:

Saturday–Monday, 2 hours before the hall opens (7 a.m.)

NO APPROVAL WILL BE GRANTED FOR ACCESS TO THE SHOW FLOOR PRIOR TO 7:00 A.M. EACH DAY.

If an exhibitor requires access to the show floor on any of these days prior to the above, the exhibitor is required to contact the exhibits manager directly. Security and the BCEC public safety officers are not permitted to grant any early access.

BADGES REQUIRED

Everyone is required to have a badge on in order to gain access to the exhibit hall.

CARE OF FACILITY

Protection of convention facility property

Nothing shall be posted on, or tacked, nailed, screwed or otherwise attached to the columns, walls, floors, or other parts of the facility or convention hall exhibit area without permission from the proper building authority. Please ask the exhibits manager.

Packing, unpacking, and assembly of exhibits shall be done only in designated areas and in conformity with the directions of the convention hall managers or their assistants.

CHILDREN IN THE EXHIBIT HALL

Due to safety considerations, under no circumstances are children allowed inside the exhibit hall during installation or dismantle.

Children under the age of 18 are required to be accompanied by an adult that has an attendee badge. Strollers are prohibited in the exhibit hall.

PROFESSIONAL BEHAVIOR

Exhibitors may not enter another exhibitor's booth. Professional behavior is expected by each company, its representatives, and exhibitor appointed contractors at all times during the ASCRS Annual Meeting.

Any provocation of another either verbally, physically, or by any other means will result in all parties involved surrendering their badges immediately and being escorted off the premises by security, and all parties being prohibited from attending the remainder of the meeting, exposition and functions.

It is at the discretion of the exhibits manager to either penalize or prohibit the parties' attendance at any future meetings held by the association.

PHOTOGRAPHING AND VIDEOTAPING

Exhibitors may not take photos or videos of other booths.

An exhibitor may photograph or videotape only within the confines of their booth.

Exhibitors who designate any third party to provide this service will be required to submit an EAC form and the EAC must submit a COI form by the noted deadline.

EACs are prohibited from videotaping outside of the assigned booth space without proper approval from the exhibits manager.

Exhibitors understand and agree that photographs of their exhibit will be taken by the official show photographer while documenting the Annual Meeting. Exhibitors agree that photos of their booth, possibly containing logos and trademarks may appear without restriction, in promotional and other documents produced by ASCRS.

SECURITY

ASCRS | ASOA will hire security guards for the public areas of the convention center.

Should you have valuable items in your booth that need to be left overnight, it is recommended that you hire the official show security company to provide security detail services. An order form will be provided in the Exhibitor Service Kit available in December.

ASCRS | ASOA is not responsible for lost, stolen or damaged items.

SELLING

Selling or order taking is permitted, however the exhibitor is expected to maintain proper decorum, follow ASCRS ASOA's high standards, and be consistent with the educational purposes and integrity of the show and profession.

Exhibitors must obtain any/all permits/licenses required by the host state/city prior to selling/taking orders on-site. All taxes related to sales/orders on-site are the sole responsibility of the exhibitor.

SELLER'S PERMITS / SALES TAX INFORMATION

A seller's permit allows you to collect sales tax from customers and report those amounts to the state on a regular reporting period (either monthly, quarterly, or annual). There is no charge for a seller's permit, but security deposits are sometimes required by the state. It is the exhibitor's responsibility to secure this permit if taxes are being collected on the show floor for the sale of any goods and services.

For further information, contact:

Department of Revenue

Toll-free in Massachusetts(800) 392-6089

8:30 a.m.–4:30 p.m., Monday through Friday

SOUND & PRESENTATIONS IN BOOTHS

When conducting a presentation in your booth, it is the exhibitor's responsibility to keep overflow crowds clear of the aisles. ASCRS reserves the right to determine whether or not sound presentations and any audiovisual being displayed are the correct decibel level.

Earphones are required for booth presentations.

Seating for presentation areas must be free and clear from the aisles and be monitored and controlled so that all aisles remain congestion free.

CONTESTS, DRAWINGS, AND RAFFLES

Exhibitors are encouraged to engage meeting attendees and add value to the meeting experience. That said, contests, drawings, raffles, entertainment and other similar activities must be reviewed and approved by the Exhibits Manager and are also subject to review by the ASCRS Marketing and Communications Department. These activities must be compatible with and maintain the professional atmosphere and tone of the Annual Meeting, as well enhance the attendee experience.

Exhibitors are not permitted to collect names or register individuals for contests, drawings, or raffles that will be held outside the Annual Meeting. Gaming devices of any description are not permitted in the exhibit hall.

EXHIBITOR BOOTH MARKETING GUIDELINES

Except where specifically provided by contractual agreement between ASCRS and the exhibiting company for sponsorships and marketing opportunities, exhibitor marketing efforts must not extend beyond the confines of the exhibit booth.

Exhibitors may not:

- Solicit attendees in lobby spaces of the convention center.
- Place or hand out promotional flyers in any locations other than their exhibit booth.
- Conduct marketing within the confines of the convention center.
- Place marketing on the sidewalks and promenade leading up to the convention center or official ASCRS hotels
- Place marketing by shuttle bus entrances, passenger drop off/pick up and taxi lines.
- Permit mobile advertising to remain stationary in front of the convention center entrances or other assigned meeting spaces.

AFFILIATE FUNCTION MARKETING GUIDELINES

You are permitted one sign in front of your meeting/event space. Signage for your meeting or event is not permitted outside the confines of a competing exhibitor's meeting or event.

Should competing companies host events in the same hotel/venue on the same day, external marketing is limited to immediately in front of your meeting/event space(s) only.

External marketing may not interfere or detract from a competing exhibitor's event or marketing.

External personnel used for marketing purposes are expected to maintain appropriate behavior and dress at all times.

E-BLAST / EMAIL MARKETING

All e-blast marketing must be approved through ASCRS prior to distribution and must contain the ASCRS disclaimer. Please contact Exhibits Manager at exhibits@ascrs.org to obtain a copy of the disclaimer and submit your e-blast marketing piece for approval by April 24, 2020.

EXHIBITOR SOCIAL MEDIA GUIDELINES

All exhibitors are encouraged to promote their Annual Meeting attendance and booth information in advance of and throughout the meeting. ASCRS has promotional tools that are available for exhibitor use. To obtain these tools, contact the ASCRS digital manager at marketing@ascrs.org.

Exhibitors are encouraged to leverage social media throughout the meeting, and must comply with the following guidelines:

- Do not amend or alter the "We're Exhibiting" image.
- Do not use the image in a way that suggests or implies partnership, sponsorship or endorsement by ASCRS.
- Keep in mind these guidelines when posting about the Annual Meeting.
- Non-flash photography is allowed for personal, social or non-commercial use.
- Please respect attendees and presenters who state they do not want their slides and/or content shared on social media.
- Exhibitors taking photos must do so in a manner that does not disturb the presenter or other attendees.
- Sharing slides that feature patient faces or other identifiable information is prohibited.

Video recording, live audio and/or video streaming is strictly prohibited. Failure to comply with this policy may result in being removed from the session and/or meeting.

EXHIBITOR PRESS RELEASES

Exhibitors may issue press releases regarding their products, data or other proprietary information available in the exhibit hall. They may also reference the fact that they are exhibiting at the ASCRS Annual Meeting and that sessions at the meeting will provide additional data or information about their products or services. However, no company shall describe the presentation of data or information at the meeting in such a way as to imply an endorsement by ASCRS.

Specifically, words such as "featured" or "showcased" must be avoided. Furthermore, no company shall issue a press release listing, by name, any official ASCRS meeting content, programming, educational sessions or other presentations.

Any press release referencing an exhibitor's participation in the meeting must also include the following disclaimer: "All educational content of the ASCRS Annual Meeting is planned by its program committee, and ASCRS does not endorse, promote, approve, or recommend the use of any products, devices, or services."

EXHIBIT BOOTH GIVEAWAYS

Items that will be used only by internal staff of the exhibiting company (and therefore not given away) are exempt from this policy.

Exhibiting companies may distribute descriptive product literature and samples of their listed products to each booth visitor.

Where permitted by law, it is appropriate for companies to offer items that are not of substantial value (\$100 or less) and do not have value to healthcare professionals outside of their professional responsibilities. For example, an anatomical model for use in the examination room is intended for the education of patients and would be acceptable.

Potential giveaway items must be designed primarily for the education of patients or healthcare professionals.

Potential giveaway items may not duplicate items ASCRS supplies with the support or promotional fees paid to ASCRS by a corporate supporter or advertiser. These items include but are not limited to: lanyards, tote bags made of an enduring material, and bottled water.

Exhibiting companies may wish to place giveaway items from their booth in a bag. Because our attendee tote bags are a sponsored item, you are required to follow the guidelines below.

1. A product sample of the bag is required to be submitted to ASCRS for prior approval.
2. The bag is required to be plastic or paper only.

Failure to provide a sample by the deadline – provided below – may preclude the exhibitor from providing a giveaway. All giveaway items must be pre-approved by the exhibits manager or will be confiscated on the show floor and not returned.

Prescription drug samples may be distributed to ophthalmologists only in accordance with the Prescription Drug Marketing Act.

Distribution of approved items must not create a nuisance or cause interference with adjoining exhibitors.

For those companies that follow the Pharmaceutical Research and Manufacturers of America's (PhRMA) Code and/or the Advanced Medical Technology Association (AdvaMed) Code, giveaways permitted for the Annual Meeting are those designed primarily for the education of patients or healthcare professionals. It is the sole responsibility of the exhibiting company to abide by the guidelines set forth by PhRMA and AdvaMed Codes.

ASCRS, at its sole discretion, shall have the right to prohibit the distribution of any item it deems objectionable or otherwise inappropriate.

You are required to gain approval for your giveaway.

Please submit a picture and short description of the items to the Exhibit Manager, at exhibits@ascrs.org by May 1, 2020.

POLICY ENFORCEMENT

Any unapproved Annual Meeting marketing and/or advertising carries with it the possibility of penalties to be assigned at the discretion of ASCRS. Penalties will be conducted in accordance with the below unless otherwise stated. Depending on the severity of the offense and/or conduct, and/or number of violations, ASCRS may opt to forgo the below and close the event.

1st offense

Verbal Warning

2nd offense

The exhibiting company will lose all priority points accrued during the calendar year and will receive no priority points for the remaining portion of the year. Additionally, the company may be prevented from exhibiting or attending the following ASCRS Annual Meeting.

3rd offense

ASCRS will prohibit the exhibiting company from exhibiting at the next ASCRS Annual Meeting. The exhibitor will lose all priority points accrued during the calendar year and will receive no priority points for the remaining portion of the year.

Again, it is not the intent of ASCRS | ASOA to interfere with exhibitor outreach and/or marketing efforts, but only to ensure that the Annual Meeting remains a fair and positive opportunity for all involved.

HELIUM BALLOONS

Helium balloons are not permitted.

PROMOTIONAL MATERIAL

Exhibitors may not use the name or logos of the American Society of Cataract and Refractive Surgery (ASCRS) or the American Society of Ophthalmic Administrators (ASOA) in promotional material without written consent from ASCRS and ASOA.

While at the exhibition, distribution of advertising material and exhibitor solicitation of any sort shall be restricted to the exhibitor's booth. Neither company nor products may extend into the aisle or beyond the limits of the assigned booth.

FOOD & BEVERAGE IN EXHIBIT BOOTHS

Exhibitors are permitted to purchase food and beverages from the convention center catering department for their booth during exhibit hall hours. Popcorn is not permitted.

GENERAL RULES AND REGULATIONS

1. These rules and regulations constitute an essential part of the contract for the exhibit space. During the Annual Meeting, the American Society of Cataract and Refractive Surgery (ASCRS) and the American Society of Ophthalmic Administrators (ASOA) reserve the right to render all interpretations and to establish further regulations as may be deemed necessary for the general success of the exhibition.
2. ASCRS reserves the right to decline, prohibit, or expel an exhibit which, in its judgment, is out of keeping with the character of the exhibition, this reservation being all inclusive as to the persons, things, printed matter, product, conduct, etc. Should the exhibit be expelled, space payments will not be refunded.
3. Exhibitors shall be bound by all pertinent laws, codes, and regulations of municipal or other authorities having jurisdiction over the exhibit facility or the conducting of said exhibit, together with the rules and regulations of the owners and/or operators of the facility in which the exhibition is held.
4. It is agreed that if the exhibitor fails to comply in any respect with the terms of the agreement, then ASCRS shall have the right, without notice to the exhibitor, to sell or offer for sale the exhibit space covered by this contract. Said exhibitor will be liable for any deficiency, loss, or damage suffered by the exhibition by reason of the premises stated, which loss or damage the exhibitor agrees to pay the exhibition upon demand together with reasonable expenses and costs incurred by reason thereof.
5. It is further agreed that actual occupation of the exhibit space by an exhibit is of the essence thereof, and that should the exhibition be unable to affect the sale of the space as herein provided, the exhibition is then expressly authorized to occupy or cause said space to be occupied in such a manner as it may deem in the best interest of the exhibition, without any rebate or allowance whatsoever to the exhibitor and without in any way releasing said exhibitor from any liability hereunder, and said exhibitor expressly agrees to pay the exhibition the full sum herein set forth.
6. ASCRS shall have full power in the interpretation and enforcement of all rules and regulations contained herein and the power to make such amendments thereto, and such further rules and regulations as it shall consider necessary for the proper conduct and success of the exhibition.
7. I understand that by providing my mailing address, email address, telephone number and fax number, I consent to receive communications sent by or on behalf of ASCRS (and their subsidiaries and affiliates) via regular mail, email, telephone or fax. I understand that ASCRS may share my address/email/telephone/fax with other organizations.

VIOLATIONS

Specific actions may be taken by ASCRS for violation of any provision of these guidelines. Violations of any ASCRS policies, guidelines, rules or regulations may result in the loss of priority points for future space assignments and/or immediate removal from the exhibit hall and/or denial of exhibit space at future meetings. The action taken will be determined on the basis of the particular circumstances of the violations, but in cases involving major violations, may include legal action.

PRIORITY POINTS

ASCRS has the discretion to reduce an exhibitor's accrued priority points based on past inappropriate conduct by the applicant (including but not limited to failure to comply with ASCRS exhibitor rules and regulations) or legal or regulatory actions or consumer/member complaints relating to the safety and efficacy of an applicant's products or services.

EVALUATION OF SPACE APPLICATION/CONTRACT

In order to preserve and maximize the educational value of the technical exhibit program, ASCRS will examine all space application/ contracts and evaluate the proposed exhibits to determine whether they satisfy certain basic criteria. Permission to exhibit does not constitute in any way an ASCRS endorsement or approval of the exhibited products or services or guarantee that space will be assigned.

The evaluation of space application will be performed in accordance with guidelines established by the ASCRS Executive Committee. The principle criteria to be considered in reviewing applications shall include, but are not limited to, whether the products or services proposed for exhibition relate specifically to the practice or advancement of ophthalmology generally and/or cataract and refractive surgery specifically, whether the proposed exhibit is of educational value to ophthalmologists, cataract and refractive surgeons, and whether the products or services in question are safe and effective.

Every exhibitor applicant who did not exhibit at the 2019 ASCRS Annual Meeting must complete the review process for assignment of exhibit space. An applicant who did exhibit in 2019 must complete the review process only if there has been a material change in circumstances relating to its company (e.g., a change in ownership, control, or legal status) or in the nature, name, composition, products, labeling, or regulatory status of the products and services to be exhibited, or if the safety or efficacy of the company's products or services have been called into question through litigation, regulatory proceedings, customer complaints, or other reliable sources of adverse information.

The information required for review are the following:

1. Company Profile
2. The products and/or services the company plans to exhibit (i.e. product brochures, literature, or samples).
3. Exhibitors must disclose details on any consumer or government litigation, orders, injunctions, judgments, or settlements over the last three years regarding the business practices of the company or the products and services to be exhibited. Companies with complaints filed against them with state or federal consumer affairs regulatory agencies, the Better Business Bureau, or ASCRS members may be required to provide an explanation of the resolution of those complaints.
4. Exhibitors shall not exhibit any products or services other than those included in their space application/contract or approved in writing by ASCRS. Successfully completing the exhibit application does not guarantee that you will be assigned booth space. ASCRS meetings consistently sell out of exhibit space and maintain waiting lists.

ASCRS exhibit space is assigned in priority point order to all exhibitors that have a history of exhibiting at ASCRS meetings.

Even where an exhibitor meets the basic criteria described above, ASCRS still reserves the right to deny any request to exhibit based on space limitations, safety concerns, failure to comply with these procedures or requirements, past inappropriate conduct by the applicant (including by not limited to failure to comply with ASCRS exhibitor rules and regulations), or a reasonable determination by ASCRS that the company's products or services are not safe and/ or effective.

Alternatively, ASCRS may decide to reduce an applicant's accrued priority points based on the applicant's past failure to comply with ASCRS exhibitor rules and regulations or legal or regulatory actions or consumer/member complaints relating to the safety and efficacy of an applicant's products or services.

CATASTROPHE

ASCRS will not be liable for the fulfillment of this contract as to the delivery of exhibit space if non-delivery is due to any of the following causes: by reason of the facility being damaged or destroyed by fire, act of God, public enemy, war or insurrections, strikes, acts of terrorism, the authority of the law, public health crisis, postponement or cancellation of the exposition, or for any cause beyond their control. It will, however, in the event of its not being able to hold an exhibit for any of the above-named reasons, reimburse exhibitors on a pro-rate basis on any amount paid in, less any and all legitimate expenses incurred, such as but not limited to rent, advertising, salaries, operating costs, etc.

OUTSTANDING BALANCE/PAYMENT INFORMATION

Companies that have a balance due from a previous show will not be permitted to exhibit in future shows until the balance due is paid in full.

If payment is not received on or before December 13, 2019, exhibitors will lose 10 priority points, per day, each day the balance is overdue.

ASCRS reserves the right to reassign or cancel the booth space without notice that is not paid in full by the deadline.

Applications received by ASCRS on or after December 14, 2019 must include 100% payment to be processed.

PROMOTIONAL MATERIAL

Exhibitors may not use the name or logos of the American Society of Cataract and Refractive Surgery or ASCRS or the American Society of Ophthalmic Administrators or ASOA in promotional material without written consent from ASCRS and ASOA.

While at the exhibition, distribution of advertising material and exhibitor solicitation of any sort shall be restricted to the exhibitor's booth. Neither company nor products may extend into the aisle or beyond the limits of the assigned booth.

 ASCRS
GLAUCOMA
DAY 2020

Sponsored by the ASCRS Glaucoma
Clinical Committee

 ASCRS
REFRACTIVE
DAY 2020

Sponsored by the ASCRS Refractive
Surgery Clinical Committee

ASCRS SUBSPECIALTY DAY 2020 EXHIBITOR GUIDE

ASCRSRefractiveDay.org

ASCRSGlaucomaDay.org

May 15, 2020

2020 INVITATION TO EXHIBIT

Dear Exhibitor:

We are pleased to invite you to exhibit at the 2020 ASCRS Subspecialty Day programs on Friday, May 15, 2020.

This exhibit hall – which is open to all attendees of ASCRS Glaucoma Day and ASCRS Refractive Day– offers a unique opportunity for exhibitors to connect with the most important target market for your company’s products and services. These one-day educational programs attracted a combined total of over 2,300 ophthalmologists and healthcare professionals in 2019.

2019 attendance totals included Cornea Day. The World Cornea Congress VIII, which meets every 5 years, will precede the 2020 ASCRS Subspecialty Day and Annual Meeting. Please contact me at jbarbera@ascrs.org for exhibit information or visit <http://www.corneasociety.org/world-cornea-congress-viii>

2019 ATTENDANCE PROFILE

Ophthalmologists	2,205
Healthcare Professional	100
Industry (Non-Exhibitor)	45
Total Attendance	2,350

Thank you for your support and interest in participating in our educational programs.

Exhibits Manager
ASCRS ASOA

EXHIBIT DATES/HOURS

Friday, May 15, 2020 7:00 a.m.–4:00 p.m.

SPACE ASSIGNMENT

ASCRS Subspecialty Day exhibits are an extension of the continuing education program. To be accepted by ASCRS, the products and services should be related to ophthalmic or medical administrative fields.

Table top exhibits will be assigned space on a first-come, first-serve basis. Exhibit space is limited; thus companies are limited to one tabletop space. Requests for additional tabletop spaces will be reviewed on an individual basis.

ASCRS reserves the right to reconfigure the exhibit hall floor plan and reassign any exhibiting company at any time. Should the affected exhibitor cancel their space as a result of his booth reassignment, space payments will be refunded in full provided the exhibits manager receives the written cancellation within the designated time frame. The affected exhibitor must submit his cancellation notification in writing within 5 days of notification of space reassignment.

The exhibit hall will be open for ASCRS Glaucoma Day and ASCRS Refractive Day attendees only:

Morning and afternoon food and beverage will be provided in the hall.

Exhibitors for ASCRS Subspecialty Day will have access to the session rooms with an ASCRS Subspecialty Day exhibitor badge, providing there is seating open for attendees.

BOOTH SPACE GUIDELINES

Exhibits are for disseminating information and displaying products that can easily fit within the allotted tabletop exhibit space. The maximum height of products and display materials on the table may not exceed 7ft. from the floor, nor can the products wrap around to produce any type of sidewall or blocking line of sight to another exhibit table. All exhibitors are required to keep their materials within their exhibit space.

Portable, pop-up back walls are permitted as long as it fits within the confines of your 6ft table space.

All exhibits are subject to review on-site and modification where necessary.

Custom-built booth displays are strictly prohibited. Any requests to substitute the 6' table with equipment must be made in writing no less than 30 days in advance of the exhibition. Please note that the exhibit hall configuration is subject to approval by the local fire marshal.

LASERS & POTENTIALLY HAZARDOUS LIGHTS

Any exhibitor who will be utilizing or displaying lasers or other hazardous optical sources will be required to review the ASCRS Laser Safety Guidelines and submit the Laser Safety Use form by March 17, 2020.

IMPORTANT DATES TO REMEMBER

Booth applications will be accepted until the exhibit area is sold out. Subspecialty Day booths payments are required to be submitted in full with the application.

December 17

Last day to cancel exhibit space without incurring a penalty

December 18, 2019-January 17, 2020

Booth cancellation will forfeit 30% of total booth fee

December 2

Exhibitor badge registration open

December 2

Exhibitor Service Kit available online

January

Exhibit space assignments emailed

January 18, 2020-March 17, 2020

Booth cancellation will forfeit 50% of total booth fee

March 18-showsite

Booth cancellation will forfeit 100% of total booth fee

March 17

Laser safety use form due

April 24

Mailing sample with pre-registration list request form due. No lists will be run after this date.

May 1

Giveaway item approval deadline

May 13-15

Exhibitor registration open

May 14

Exhibit installation 1:00–5:00 p.m.

May 15

Exhibit hall open 7:00 a.m.–4:00 p.m.

May 15

Exhibit dismantle 4:00–6:00 p.m.

ASCRS SUBSPECIALTY DAY TABLE TOP EXHIBIT DISPLAY GUIDELINES

Exhibitors will be asked to remove any exhibits not in compliance with these guidelines

YOUR EXHIBIT SPACE INCLUDES:

- One draped table, 6' long x 2' deep x 30" High. The table is topped in a black skirt.
- Standard ID sign on your table. 11" long x 17" high.
- Two chairs
- One wastebasket

YOU ARE RESPONSIBLE FOR ORDERING ELECTRIC AND INTERNET IF NEEDED AT YOUR EXHIBIT TABLE.

IMPORTANT NOTE REGARDING ELECTRIC:

Electric can be ordered; however, you **MUST** notify the ASCRS Exhibits Manager in advance so that your table is assigned near electric ports. Please advise when submitting your application.

FLOOR COVERING

The exhibit hall for ASCRS Subspecialty Day will be carpeted, and companies are prohibited from providing their own floor covering.

HANGING SIGNS

Hanging signs are not permitted within the ASCRS Subspecialty Day exhibit area.

TABLE DISPLAY GUIDELINES:

- Table top height may not exceed 7ft, exhibit fixtures, signage, products, etc. must be placed on top of the table top.
- Equipment carts are permitted in lieu of provided table.
- Carts must not exceed display area limits of 66" high x 6' long x 24" deep.
- Display space may not extend beyond the table surface.
- Signs or banners reaching a maximum of 6' long x 30" high may be hung from the drape on the front of the table.
- Maximum height permitted on top of the table is 3" high.

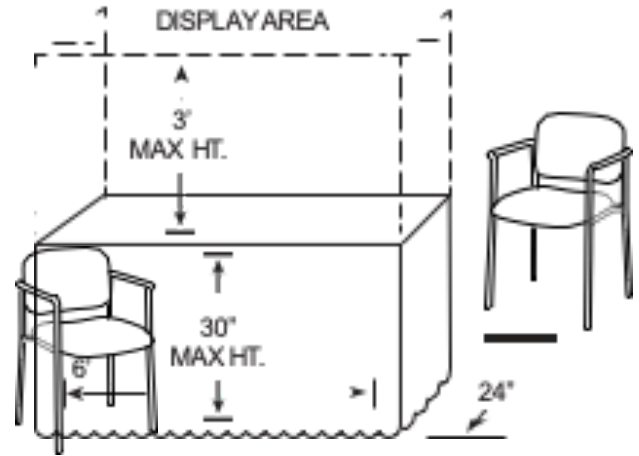

YOUR TABLE TOP IS YOUR ONLY DISPLAY SPACE

- The Exhibit area is carpeted, no other flooring is allowed.
- Free standing signage is permitted **BEHIND** your table only not next to it.
- Pop-up displays are permitted on top of your table or behind it, not next to your table.
- Additional furniture will not be permitted, nor will ordering additional chairs or a different size tables be permitted.

EXHIBIT SPACE RENTAL FEES

Fee: \$5,000

Items included in the booth fee are:

Two (2) complimentary ASCRS Subspecialty Day exhibitor badges

1250 priority points toward exhibiting at the 2021 ASCRS Annual Meeting will apply for your participation in Subspecialty Day

Company listing in the show issue of EyeWorld News Magazine
Company listing in the ASCRS Subspecialty Day Final Program
Company listing in the meetings app

ASCRS accepts American Express, Discover Card, MasterCard, VISA, Checks, and wire transfers.

PAYING BY CHECK:

Checks are to be made out to the American Society of Cataract and Refractive Surgery.

Checks are to be drawn on U.S. bank accounts only.

Check payments must accompany a copy of your booth space application and may be mailed to:

ASCRS
Attn: Exhibits Manager 4000 Legato Road, Suite 700
Fairfax, VA 22033

WIRE TRANSFER:

THE TRANSACTION FEE MUST BE INCLUDED IN THE TOTAL WIRE AMOUNT.

ASCRS IS NOT RESPONSIBLE FOR THIS AMOUNT AND YOU WILL BE BILLED FOR THE BALANCE.

Please ask your banking institution for the transaction fee amount to include. Wire details will not be provided until completed booth space application has been submitted.

Please contact the exhibits manager for wire instructions.

CANCELLATION POLICY

Cancellation of assigned booth space must be submitted in writing to the exhibits manager. Cancellations will not be taken on the phone.

Upon cancellation of exhibit space, exhibitor is responsible for canceling any hotel rooms and/or meeting space that may have been on hold.

Exhibitors canceling after booth space has been contracted will forfeit a percentage of the total space fee based on the following schedule:

- 150 days from show date (December 17, 2019)–120 days from show date (January 17, 2020) forfeit 30% of total booth fee
- 119 days from show date (January 18, 2020)–60 days from show date (March 17, 2020) forfeit 50% of total booth fee
- 59 days from show date (March 18, 2020)–0 days from show date forfeit 100% of total booth fee

Exhibitors that fail to agree to (pay) the cancellation fee will not be permitted to exhibit at future ASCRS meetings until the balance is paid in full.

OUTSTANDING BALANCES/PAYMENTS DUE

Companies that have an outstanding balance due from a previous meeting for booths or marketing purchases will not be permitted to exhibit until the balance is paid in full.

OFFICIAL HOTELS

The official housing management company for ASCRS is onPeak.

Housing opened on-site at the 2019 ASCRS Annual Meeting in San Diego. and is open to all exhibiting companies.

ONPEAK

Domestic Phone: (800) 370-8282
International Phone: (312) 527-7300
Email: ascrs-asa@onpeak.com

ASCRS has contracted rooms in Boston, MA for the 2020 Annual Meeting. These hotels are considered "official" hotels.

ANY HOTELS NOT LISTED HERE ARE NOT WITHIN THE ASCRS BLOCK AND ARE NOT PROTECTED BY ONPEAK AND ASCRS.

PRIORITY POINTS FOR HOUSING

Exhibitors are required to secure all sleeping rooms through onPeak. In doing so, exhibitors have the ability to accrue or lose priority points.

Exhibitors that utilize onPeak for 100% of their housing needs receive ten (10) times their booth square feet in priority points toward the 2021 Annual Meeting. Exhibitors who do not utilize onPeak their housing needs will lose priority points for the 2021 Annual Meeting equal to 50% of their total booth square feet. Please see the priority points section of the Exhibitor Prospectus for more details on how priority points are calculated.

SECURING HOUSING

In order to secure your exhibitor room(s) or block, you will need to submit your request online. This will notify onPeak of your requested housing needs and on which nights you will need them for your staff.

Any exhibitor requesting a room block of 20 rooms or more will be required to accept the terms of the ASCRS Attrition Agreement along with their Exhibitor Room Block Request online.

ASCRS reserves the right to make adjustments to your room block based on your organization's history of rooms reserved vs. rooms utilized. Any request for an increase in excess of 5% of your total room pick-up from the previous year will only be granted when extenuating circumstances exist; this is subject to approval by the exhibits manager.

The exhibitor room blocks will be limited at some locations.

A Maximum of 30 rooms can be booked at the following hotels:

- Westin Waterfront
- Renaissance Waterfront

For all other hotels, onPeak/ASCRS will try and accommodate each groups needs based on availability as best as possible. Your group may need to be split up between multiple hotels.

When requesting any type of suite, please note that it will count for more than one room hotel allotment.

A one-bedroom suite will count as two rooms and a two-bedroom suite will count as three rooms.

All requests for suites that will be used as sleeping rooms must go through onPeak.

Hospitality Suite requests for the purpose of meetings or entertaining must be requested through the Affiliate Function Process. Please see guidelines in the Exhibitor Prospectus for more details on Affiliate Functions or contact the Exhibit Manager for details. exhibits@ascrs.org

ROOM ASSIGNMENT AND CONFIRMATION

All housing assignments will be made in the order they are received. If your hotel choices are not available, an assignment will be made in a hotel comparable to your requested choices.

ONPEAK WILL SEND YOU A CONFIRMATION OF YOUR HOTEL ASSIGNMENT AFTER THE CUT OFF TIME PERIOD.

You will be able to distinguish email communications from onPeak, the official housing management company, as they will have the ASCRS 2020 official meeting logo within the communication and official onPeak seal.

There are many companies that try to pose as the official ASCRS housing management company. Please contact ASCRS directly if you are uncertain of the designation of a company that has been contacting you.

ROOMING LISTS:

Exhibitor group block rooming lists are due to onPeak by March 6, 2020.

RULES & REGULATIONS

ASCRS Show Rules & Regulations detailed within the 2020 ASCRS Exhibitor Guide are in effect.

AFFILIATE FUNCTIONS & MEETING SPACE

All meeting space requests are subject to the Meeting Space Guidelines & Procedures. Please refer to the affiliate functions information in the Exhibitor Prospectus or contact Exhibit Manager, at exhibits@ascrs.org for more details.

INSTALLATION OF EXHIBITS

Installation hours:

Thursday, May 14 1:00–5:00 p.m.

All exhibit crates must be empty and tagged and removed for storage no later than 5:00 p.m.

Display space not claimed and occupied by 5:00 p.m. on Thursday, May 14, may be canceled or reassigned without notification or refund.

If the exhibit is on hand, ASCRS reserves the right to assign labor to set up any display that is not in the process of being erected by 4:30 p.m. on this day and/or order the removal of all display materials and crates not in the process of being set up by 4:30 p.m. on this day.

The charge for labor to complete either of these options will be billed to the exhibitor and ASCRS shall have no liability for such work. Labor within the booth can be provided either through an exhibitor appointed contractor (EAC) or Freeman. All individuals working in the hall must be badged at all times.

ALL INSTALLATION MUST BE COMPLETED AND BE SHOW READY BY 5:00 P.M., THURSDAY, MAY 14, 2020

Exhibit booths must be staffed during all open show hours.

Exhibitor badges for ASCRS Subspecialty Day will grant access to the ASCRS Glaucoma Day and ASCRS Refractive Day session rooms. CME credits cannot be claimed with exhibitor badges.

DISMANTLE OF EXHIBITS

Dismantle hours:

Friday, May 15 4:00-6:00 p.m.

All exhibitor displays or materials left in the hall after 6p.m. will be packed and shipped at the discretion of ASCRS and all applicable service charges will be applied to the exhibitor of record.

IN NO CASE WILL DISMANTLING BE ALLOWED BEFORE 4 P.M., ON THIS DAY.

If exhibitor violates this regulation, they may lose priority points for future booth assignments or may be denied exhibit space in future trade expositions.

Please book your travel arrangements accordingly.

ASCRS SUBSPECIALTY DAY TABLE TOP EXHIBIT AGREEMENT FORM

Please review the Tabletop Display Guidelines on the previous page. You are required to sign and return this form to Exhibits Manager at exhibits@ascrs.org along with your booth contract in order for it to be considered complete.

I have read and agree to comply with the ASCRS Subspecialty Day Exhibit Guidelines. I understand ASCRS and Freeman reserves the right to require modifications to my table top exhibit on-site should it be deemed out of compliance.

NAME _____

COMPANY _____

SIGNATURE _____

DATE _____

Please return to Exhibits Manager along with your booth contract
Email: exhibits@ascrs.org
Fax: (703) 547-8840

ASCRS SUBSPECIALTY DAY EXHIBIT SPACE APPLICATION

MAY 15, 2020 • BOSTON, MA • BOSTON CONVENTION AND EXHIBITION CENTER

Please tell us which program your company's focus is towards - Please check all that apply:

ASCRS GLAUCOMA DAY ASCRS REFRACTIVE DAY

COMPANY INFORMATION — PUBLISHED IN THE FINAL.

COMPANY NAME

ADDRESS 1

CITY

STATE

ZIP

COUNTRY

PHONE

WEBSITE

CONTACT INFORMATION (FOR INTERNAL USE ONLY)

CEO/PRESIDENT

MARKETING CONTACT

MARKETING CONTACT EMAIL

EXHIBIT CONTACT

TITLE

EXHIBIT CONTACT PHONE

EXHIBIT CONTACT EMAIL

PAYMENT METHOD—PLEASE CHECK ONE.

VISA MasterCard AMEX Discover Check Wire Transfer (wire transfer fee must be included)

AMOUNT ENCLOSED \$

ACCOUNT NUMBER

EXPIRATION DATE

CODE

NAME OF CARDHOLDER

SIGNATURE OF CARDHOLDER

AUTHORIZATION: Contracts will not be processed unless signed and include payment. I am an authorized representative of the company with full power and authority to sign and deliver this application and contract. The company listed on this application agrees to comply with all the policies, rules, and regulations contained in the Exhibitor Prospectus and all policies, rules, and regulations adopted after publication of the guide.

AUTHORIZED OFFICER SIGNATURE

DATE

Please complete the application/contract as well as the company listing information and mail, fax or email to:

Mail: ASCRS/Attn: Exhibits Manager/SDEX Fax: (703) 547-8840

Email: exhibits@ascrs.org 4000 Legato Rd., Suite 700 Fairfax, VA 22033



WORLD **VIII** CORNEA **VIII** CONGRESS

WORLD CORNEA CONGRESS EXHIBITOR GUIDE

May 14-15, 2020

2020 INVITATION TO EXHIBIT

Dear Exhibitor:

The Cornea Society welcomes you to participate in the World Cornea Congress VIII (WCCVIII), to be held from May 14-15, 2020 in Boston, Massachusetts.

As the Cornea Society's premier educational and research meeting, this event is held only every five years and is a not-to-be-missed opportunity. Over 1600 ophthalmologists from around the globe are expected to attend.

The multi-day exhibit hall, immediately preceding the ASCRS Annual Meeting, gives you direct access to the most important target market for your company's products and services.

2015 ATTENDANCE PROFILE

Ophthalmologists	1,606
Healthcare Professional	54
Industry (Non-Exhibitor)	35
Total Attendance	1,695

Thank you for your support and interest in participating in our educational programs.

Exhibits Manager ASCRS ASOA

EXHIBIT DATES/HOURS

Thursday, May 14 7:00 a.m.–4:00 p.m.
Friday, May 15 7:00 a.m.–4:00 p.m.

SPACE ASSIGNMENT

WCCVIII exhibits are an extension of the continuing education program. To be accepted by ASCRS and the Cornea Society, the products and services should be related to ophthalmic or medical administrative fields.

Table top exhibits will be assigned space on a first-come, first-serve basis. Exhibit space is limited; thus, companies are limited to one tabletop space. Requests for additional tabletop spaces will be reviewed on an individual basis.

ASCRS and The Cornea Society reserves the right to reconfigure the exhibit hall floor plan and reassign any exhibiting company at any time. Should the affected exhibitor cancel their space as a result of his booth reassignment, space payments will be refunded in full provided the exhibits manager receives the written cancellation within the designated time frame. The affected exhibitor must submit his cancellation notification in writing within 5 days of notification of space reassignment.

The exhibit hall will be open for WCCVIII attendees only.

Morning and afternoon food and beverage will be provided in the hall each day.

Exhibitors for WCCVIII will have access to the session rooms with a WCCVIII exhibitor badge, providing there is seating open for attendees.

BOOTH SPACE GUIDELINES

Exhibits are for disseminating information and displaying products that can easily fit within the allotted tabletop exhibit space. The maximum height of products and display materials on the table may not exceed 7ft. from the floor, nor can the products wrap around to produce any type of side wall or blocking line of sight to another exhibit table. All exhibitors are required to keep their materials within their exhibit space.

Portable, pop-up back walls are permitted as long as it fits within the confines of your 6ft table space.

All exhibits are subject to review on-site and modification where necessary.

Custom-built booth displays are strictly prohibited. Any requests to substitute the 6' table with equipment must be made in writing no less than 30 days in advance of the exhibition. Please note that the exhibit hall configuration is subject to approval by the local fire marshal.

LASERS & POTENTIALLY HAZARDOUS LIGHTS

Any exhibitor who will be utilizing or displaying lasers or other hazardous optical sources will be required to review the ASCRS Laser Safety Guidelines and submit the Laser Safety Use form by March 17, 2020.

IMPORTANT DATES TO REMEMBER

Booth applications will be accepted until the exhibit area is sold out. WCCVIII exhibit payments are required to be submitted in full with the application.

December 17

Last day to cancel exhibit space without incurring a penalty

December 18, 2019-January 17, 2020

Booth cancellation will forfeit 30% of total booth fee

December 2

Exhibitor badge registration open

December 2

Exhibitor Service Kit available online

January

Exhibit space assignments emailed

January 18, 2020-March 17, 2020

Booth cancellation will forfeit 50% of total booth fee

March 18-showsite

Booth cancellation will forfeit 100% of total booth fee

March 17

Laser safety use form due

April 24

Mailing sample with pre-registration list request form due. No lists will be run after this date.

May 1

Giveaway item approval deadline

May 13-15

Exhibitor registration open

May 13

Exhibit installation 1:00–5:00 p.m.

May 14 & May 15

Exhibit hall open 7:00 a.m.–4:00 p.m.

May 15

Exhibit dismantle 4:00–6:00 p.m.

WCCVIII TABLE TOP EXHIBIT DISPLAY GUIDELINES

Exhibitors will be asked to remove any exhibits not in compliance with these guidelines

YOUR EXHIBIT SPACE INCLUDES:

- One draped table, 6' long x 2' deep x 30" High. The table is topped in a black skirt.
- Standard ID sign on your table. 11" long x 17" high.
- Two chairs
- One wastebasket

YOU ARE RESPONSIBLE FOR ORDERING ELECTRIC AND INTERNET IF NEEDED AT YOUR EXHIBIT TABLE.

IMPORTANT NOTE REGARDING ELECTRIC:

Electric can be ordered; however, you **MUST** notify the ASCRS Exhibits Manager in advance so that your table is assigned near electric ports. Please advise when submitting your application.

FLOOR COVERING

The exhibit hall for WCCVIII will be carpeted, and companies are prohibited from providing their own floor covering.

HANGING SIGNS

Hanging signs are not permitted within the WCCVIII exhibit area.

TABLE DISPLAY GUIDELINES:

- Table top height may not exceed 7ft, exhibit fixtures, signage, products, etc. must be placed on top of the table top.
- Equipment carts are permitted in lieu of provided table. Carts must not exceed display area limits of 66" high x 6' long x 24" deep.
- Display space may not extend beyond the table surface.
- Signs or banners reaching a maximum of 6' long x 30" high maybe hung from the drape on the front of the table.
- Maximum height permitted on top of the table is 3" high.
- The Exhibit area is carpeted, no other flooring is allowed.
- Free standing signage is permitted **BEHIND** your table only not next to it.
- Pop-up displays are permitted on top of your table or behind it, not next to your table.
- Additional furniture will not be permitted, nor will ordering additional chairs or a different size tables be permitted.

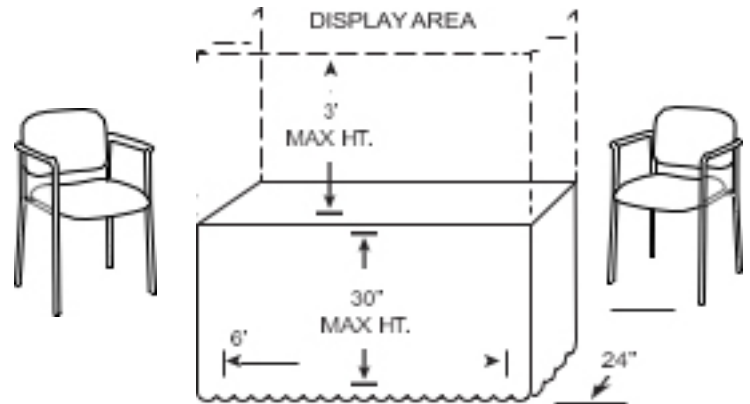

EXHIBIT SPACE RENTAL FEES

Fee: \$7,500

Items included in the booth fee are as follows:

Two (2) complimentary WCCVIII exhibitor badges

1,875 priority points toward exhibiting at the 2021 ASCRS Annual Meeting will apply for your participation at the WCCVIII.

Company listing in the show issue of EyeWorld News Magazine
Company listing in the WCCVIII Final Program
Company Listing in the meetings app

ASCRS accepts American Express, Discover Card, MasterCard, VISA, Checks, and wire transfers.

PAYING BY CHECK:

Checks are to be made out to the American Society of Cataract & Refractive Surgery.

Checks are to be drawn on U.S. bank accounts only.

Check payments must accompany a copy of your booth space application and may be mailed to:

ASCRS/WCCVIII

Attn: Exhibits Manager 4000 Legato Road, Suite 700
Fairfax, VA 22033

WIRE TRANSFER:

THE TRANSACTION FEE MUST BE INCLUDED IN THE TOTAL WIRE AMOUNT.

ASCRS IS NOT RESPONSIBLE FOR THIS AMOUNT AND YOU WILL BE BILLED FOR THE BALANCE.

Please ask your banking institution for the transaction fee amount to include. Wire details will not be provided until completed booth space application has been submitted.

Please contact the exhibits manager for wire instructions.

CANCELLATION POLICY

Cancellation of assigned booth space must be submitted in writing to the exhibits manager. Cancellations will not be taken on the phone.

Upon cancellation of exhibit space, exhibitor is responsible for canceling any hotel rooms and/or meeting space that may have been on hold.

Exhibitors canceling after booth space has been contracted will forfeit a percentage of the total space fee based on the following schedule:

- 150 days from show date (December 17, 2019)–120 days from show date (January 17, 2020) forfeit 30% of total booth fee
- 119 days from show date (January 18, 2020)–60 days from show date (March 17, 2020) forfeit 50% of total booth fee
- 59 days from show date (March 18, 2020)–0 days from show date forfeit 100% of total booth fee

Exhibitors that fail to agree to (pay) the cancellation fee will not be permitted to exhibit at future ASCRS meetings until the balance is paid in full.

OUTSTANDING BALANCES/PAYMENTS DUE

Companies that have an outstanding balance due from a previous meeting for booths or marketing purchases will not be permitted to exhibit until the balance is paid in full.

OFFICIAL HOTELS

The official housing management company for ASCRS is onPeak.

Housing opened on-site at the 2019 ASCRS Annual Meeting in San Diego. and is open to all exhibiting companies.

ONPEAK

Domestic Phone: (800) 370-8282
International Phone: (312) 527-7300
Email: ascrs-asa@onpeak.com

ASCRS has contracted rooms in Boston, MA for the 2020 Annual Meeting. These hotels are considered "official" hotels.

ANY HOTELS NOT LISTED HERE ARE NOT WITHIN THE ASCRS BLOCK AND ARE NOT PROTECTED BY ONPEAK AND ASCRS.

PRIORITY POINTS FOR HOUSING

Exhibitors are required to secure all sleeping rooms through onPeak. In doing so, exhibitors have the ability to accrue or lose priority points.

Exhibitors that utilize onPeak for 100% of their housing needs receive ten (10) times their booth square feet in priority points toward the 2021 Annual Meeting. Exhibitors who do not utilize onPeak their housing needs will lose priority points for the 2021 Annual Meeting equal to 50% of their total booth square feet. Please see the priority points section of the Exhibitor Guide for more details on how priority points are calculated.

SECURING HOUSING

In order to secure your exhibitor room(s) or block, you will need to submit your request online. This will notify onPeak of your requested housing needs and on which nights you will need them for your staff.

Any exhibitor requesting a room block of 20 rooms or more will be required to accept the terms of the ASCRS Attrition Agreement along with their Exhibitor Room Block Request online.

ASCRS reserves the right to make adjustments to your room block based on your organization's history of rooms reserved vs. rooms utilized. Any request for an increase in excess of 5% of your total room pick-up from the previous year will only be granted when extenuating circumstances exist; this is subject to approval by the exhibits manager.

The exhibitor room blocks will be limited at some locations.

A Maximum of 30 rooms can be booked at the following hotels:

- Westin Waterfront
- Renaissance Waterfront

For all other hotels, onPeak/ASCRS will try and accommodate each groups needs based on availability as best as possible. Your group may need to be split up between multiple hotels.

When requesting any type of suite, please note that it will count for more than one room hotel allotment. A one-bedroom suite will count as two rooms and a two-bedroom suite will count as three rooms.

All requests for suites that will be used as sleeping rooms must go through onPeak.

Hospitality Suite requests for the purpose of meetings or entertaining must be requested through the Affiliate Function Process. Please see guidelines in the Exhibitor Prospectus for more details on Affiliate Functions or contact the Exhibit Manager for details. exhibits@ascrs.org

ROOM ASSIGNMENT AND CONFIRMATION

All housing assignments will be made in the order they are received. If your hotel choices are not available, an assignment will be made in a hotel comparable to your requested choices.

ONPEAK WILL SEND YOU A CONFIRMATION OF YOUR HOTEL ASSIGNMENT AFTER THE CUT OFF TIME PERIOD.

You will be able to distinguish email communications from onPeak, the official housing management company, as they will have the ASCRS 2020 official meeting logo within the communication and official onPeak seal.

ROOMING LISTS:

Exhibitor group block rooming lists are due to onPeak by March 6, 2020.

RULES & REGULATIONS

ASCRS Show Rules & Regulations detailed within the 2020 ASCRS Exhibitor Guide are in effect.

AFFILIATE FUNCTIONS & MEETING SPACE

All meeting space requests are subject to the Meeting Space Guidelines & Procedures. Please refer to the affiliate functions information in the Exhibitor Guide or contact the Exhibits Manager at exhibits@ascrs.org for more details.

INSTALLATION OF EXHIBITS

Wednesday, May 13 1:00–5:00 p.m.

All exhibit crates must be empty and tagged and removed for storage no later than 5:00 p.m.

Display space not claimed and occupied by 5:00 p.m. on Wednesday, May 13, may be canceled or reassigned without notification or refund.

If the exhibit is on hand, ASCRS and The Cornea Society reserves the right to assign lab or to setup any display that is not in the process of being erected by 4:30 p.m. on this day and/or order the removal of all display materials and crates not in the process of being setup by 4:30 p.m. on this day.

The charge for labor to complete either of these options will be billed to the exhibitor and ASCRS and The Cornea Society shall have no liability for such work. Labor within the booth can be provided either through an exhibitor appointed contractor (EAC) or Freeman. All individuals working in the hall must be badged at all times.

DISMANTLE OF EXHIBITS

Friday, May 15 4:00–6:00 p.m.

All exhibitor displays or materials left in the hall after 6 p.m. will be packed and shipped at the discretion of ASCRS and The Cornea Society and all applicable service charges will be applied to the exhibitor of record.

If exhibitor violates this regulation, they may lose priority points for future booth assignments or may be denied exhibit space in future trade expositions.

Please book your travel arrangements accordingly.

Exhibitor badges for WCCVIII will grant access to the WCCVIII session rooms. CME credits cannot be claimed with exhibitor badges.

WCCVIII TABLE TOP EXHIBIT AGREEMENT FORM

Please review the Tabletop Display Guidelines on the previous page. You are required to sign and return this form to the Exhibits Manager at exhibits@ascrs.org along with your booth contract in order for it to be considered complete.

I have read and agree to comply with the WCCVIII Exhibit Guidelines. I understand ASCRS, The Cornea Society and Freeman reserves the right to require modifications to my table top exhibit on-site should it be deemed out of compliance.

NAME

COMPANY

SIGNATURE

DATE

Please return to Exhibits Manager along with your booth contract

Email: exhibits@ascrs.org

Fax: (703) 547-8840

WCCVIII EXHIBIT SPACE APPLICATION

MAY 13-15, 2020 • BOSTON, MA • BOSTON CONVENTION AND EXHIBITION CENTER

COMPANY INFORMATION —PUBLISHED IN THE FINAL.

COMPANY NAME _____

ADDRESS 1 _____

CITY _____

STATE _____

ZIP _____

COUNTRY _____

PHONE WEBSITE _____

CONTACT INFORMATION (FOR INTERNAL USE ONLY)

CEO/PRESIDENT _____

MARKETING CONTACT _____

MARKETING CONTACT EMAIL _____

EXHIBIT CONTACT _____

TITLE _____

EXHIBIT CONTACT PHONE _____

EXHIBIT CONTACT EMAIL _____

PAYMENT METHOD—PLEASE CHECK ONE.
 VISA MasterCard AMEX Discover Check Wire Transfer (wire transfer fee must be included)

AMOUNT ENCLOSED \$ _____

ACCOUNT NUMBER _____

EXPIRATION DATE _____

CODE _____

NAME OF CARDHOLDER _____

SIGNATURE OF CARDHOLDER _____

AUTHORIZATION: Contracts will not be processed unless signed and include payment. I am an authorized representative of the company with full power and authority to sign and deliver this application and contract. The company listed on this application agrees to comply with all the policies, rules, and regulations contained in the Exhibitor Prospectus and all policies, rules, and regulations adopted after publication of the guide.

AUTHORIZED OFFICER SIGNATURE _____

DATE _____

Please complete the application/contract as well as the company listing information and mail, fax or email to:

 Mail: ASCRS/Attn: Exhibits Manager/WCCVIII Fax: (703) 547-8840 Email: exhibits@ascrs.org
 4000 Legato Rd., Suite 700 Fairfax, VA 22033

COMPANY LISTING INFORMATION (Must accompany application)

Please provide a company description in 100 words or less for publication in the World Cornea Congress VIII Final Program. If no company description is supplied, the company name, address, telephone number, and booth number will be the only information published in the program.

